



Grant Agreement no.: **212825**

Project acronym: **PROTEST**

Project title:
PROcedures for TESTING and measuring wind energy systems

Instrument: Collaborative Project

Thematic Priority: **FP7-ENERGY-2007-1-RTD**

Deliverable D1: State-of-the-Art-Report

Date of preparation: 02.04.09

Authors:

Kimon Argyriadis	(GL)	Luc Rademakers	(ECN)
Mark Capellaro	(USTUTT)	Milan Ristow	(GL)
Stefan Hauptmann	(USTUTT)		
Markus Kochmann	(GL)		
Fragiskos Mouzakis	(CRES)		

WP Leader: Stefan Hauptmann (USTUTT)

Start date of project: 01.03.2008

Duration: 30 months

Organisation name of lead contractor for this deliverable: Universität Stuttgart, Germany

Project co-funded by the European Commission within the Seventh Framework Programme (2007-2013)

Dissemination level

PU	Public	x
PP	Restricted to other programme participants (including the Commission Services)	
RE	Restricted to a group specified by the consortium (including the Commission Services)	
CO	Confidential, only for members of the consortium (including the Commission Services)	

Abstract

In this report the present-day design and testing methods of wind turbine components are presented with a particular focus on the wind turbine gearbox, pitch system and yaw system. The report lists the common drive train concepts and describes the actual component design procedure starting from aeroelastic turbine simulations to limit states analysis and verification. Specific attention is given to the present-day method of load transfer from the global aeroelastic simulations to the component design loads and the pitfalls in the current design procedure. Furthermore, the report presents the state-of-the-art measurement approach and how the measurements are used to support the design process and certification of a wind turbine and its components. Special attention is given to the procedures that derive life time loads from measurement loads.

As another main focus of this report, different load validation procedures are discussed. Since measurement data are used for the validation of design loads, different approaches are currently used to compare the measurement quantities and the design values. The design and certification of wind turbines is based on a number of guidelines and standards. These are summarised and evaluated in this report. Also, the practice of wind turbine type certification and project certification is taken into account.

The conclusions of this report will establish why the PROTEST project is necessary, and proposals for improved design as well as for the measurement and certification approaches are derived from the conclusions of this report.

Acknowledgement

This report is the result of work jointly carried out by the participants of Work Package 1 of the PROTEST project "*PROcedures for TESTing and measuring wind energy systems*": University of Stuttgart, ECN, CRES and Germanischer Lloyd. The contributions of the other project partners DEWI, Hansen, and Suzlon is kindly acknowledged.

Table of Contents

1. Introduction.....	7
1.1 PROTEST project.....	7
1.2 Scope of the Report.....	9
2. State-of-the-art design approach.....	11
2.1 Recent developments in wind turbine technology.....	11
2.1.1 Increase in size and power.....	11
2.1.2 Drive train concepts.....	13
2.1.3 Pitch system.....	18
2.1.4 Yaw system.....	19
2.2 Determination of design load cases.....	19
2.2.1 IEC 61400-1.....	20
2.2.2 GL guidelines.....	22
2.2.3 IEC 61400-4.....	22
2.3 Simulation of overall wind turbine loads.....	23
2.3.1 Wind turbine design approach.....	23
2.3.2 Simulation tools.....	23
2.3.3 Sources for loads.....	24
2.4 Determination of component design loads and design stresses.....	26
2.4.1 Drive train design loads.....	26
2.4.2 Pitch system design loads.....	27
2.4.3 Yaw system design loads.....	27
2.5 Determination of components design strength and of limit state analyses.....	27
2.5.1 Component design strength.....	27
2.5.2 Limit state analysis.....	28
2.5.3 Resonance analysis.....	28
2.6 Pitfalls in the current design practices.....	28
2.6.1 Finding the maximum stress response.....	28
2.6.2 Data transfer between parties.....	28
2.6.3 Design load cases not determined.....	29
2.6.4 Limitations in simulation abilities.....	29
3. State-of-the-art measurement approaches.....	30
3.1 Introduction.....	30
3.2 Power performance and load measurements according to IEC 61400.....	30
3.2.1 Power performance and wind inflow measurements.....	30
3.2.2 Mechanical load measurements.....	31
3.2.3 Power quality measurements.....	33
3.3 Measurement load cases according to IEC.....	34
3.4 Extrapolation of measured loads to lifetime loads.....	34
3.5 State of the art testing procedures.....	35
3.6 Pitfalls in the current validation practices.....	36
4. Comparison of design and measurement approaches.....	37
4.1 Results of Benchmark exercises.....	37
4.2 Practical experiences.....	38
4.2.1 Motivation.....	38
4.2.2 Approach.....	38
4.3 Final remarks.....	41
5. Status and trends of standards and certification procedures.....	42
5.1 Assessment of site and operational conditions and associated load cases.....	43
5.2 Numerical and experimental determination of component loads.....	44
5.2.1 Introduction.....	44
5.2.2 Determination of component loads.....	44
5.2.3 Verification of component loads, resonance analysis.....	45

5.3	Component design strength and limit state analyses.....	46
5.3.1	Structural components.....	46
5.3.2	Gearboxes	46
5.4	Turbine and project certification practice.....	47
5.4.1	Introduction	47
5.4.2	Wind turbine type certification.....	47
5.4.3	Project Certification.....	49
6.	Conclusions and recommendations for ProTest project	51
7.	Outlook and Proposal for improved design, measurement and certification approaches.....	52
7.1	General	52
7.2	Improved design approach	53
7.3	Improved measurement procedures	54
7.4	Improvement of standards and certification	54
7.5	Improvement of data exchange	55
8.	References	56
Appendix A	60
Evaluation of component failures and associated O&M costs	60	60
A 1: Wind turbine technical availability.....	60	60
A 2: Field performance and wind turbine inspection	63	63
A 3: Failure rates of main components	65	65
A 4: O&M costs and loss of production associated with failure of main components.....	68	68
A 5: Prospects for improvement of profitability for manufacturers and operators.....	69	69

List of Figures

Figure 1.1: Schematic presentation of transforming "global turbine loads" to "local components loads" at nine interfaces, (gearbox, pitch system and yaw system).....	8
Figure 2.1: Global cumulative installed capacity 1996 – 2007 [20].....	11
Figure 2.2: Global annual installed capacity 1996 – 2007 [20]	11
Figure 2.3: Annual installed capacity by region 2003 – 2007 [20].....	12
Figure 2.4: Development of the size of wind turbines [54]	12
Figure 2.5: Top-10 suppliers in 2007.....	13
Figure 2.6: Overview of common drive train concepts	13
Figure 2.7: Modular drive train with two main bearings using the example of REpower 5M (Source REpower).....	14
Figure 2.8: Modular drive train with 3-point suspension using the example of Suzlon S88 (Source: Suzlon).....	14
Figure 2.9: Integrated drivetrain using the example of Vestas V90-3MW (Source: Vestas).....	15
Figure 2.10: WinWind WWD-1 with hybrid design (Source: WinWind).....	15
Figure 2.11: Enercon E82 with direct drive, synchronous generator, permanently excited rotor (Source: Enercon)	16
Figure 2.12: Vensys V77, direct drive, synchronous generator, permanent magnet generator (Source: Vensys).....	16
Figure 2.13: Wind turbine design process [16].....	23
Figure 2.14: Modelling of a wind turbine for aeroelastic simulations using the code Flex5 (Source: Vestas).....	24
Figure 4.1: Example of plots to verify the wind conditions (turbulence and wind shear)	39
Figure 4.2: Edgewise (left) and flap wise (right) bending moment of rotor blade.....	39
Figure 4.3: Flap wise bending moment of rotor blade (y-axis) as a function of the wind speed at hub height (x-axis) (left: max, mean, min values; right: standard deviation).....	40
Figure 4.4: Sum in plane blade bending moments as a function of the main shaft torque	40

Figure 4.5: Blade flatwise bending moment, measured and calculated.....	41
Figure 5.2: Fatigue Analysis procedure.....	46
Figure 5.3: Modules of Type Certification.....	48
Figure 5.4: Modules of Project Certification	49
Figure 7.1: Design and development process of rotor blades.....	53
Figure 7.2: Design and development process of other mechanical components	53
Figure A.1: Failure rates of wind turbines categorized by rated power [24].....	61
Figure A.2: Distribution of numbers of failures [49].....	65
Figure A.3: Average downtime in case of component damage [49]	66
Figure A.4: Percentage of downtime per component in Sweden (2000-2004) [49]	66
Figure A.5: Relative component costs for a state-of-the-art wind turbine with rated power of about 2MW	68

List of Tables

Table 2-1: Overview of the installed offshore wind power capacity (end of 2007).....	12
Table 2-2: Design load cases for wind turbines specified in IEC 61400-1	21
Table 3-1: Quantities to be measured according to IEC/TS 61400-13 [33].	33
Table 3-2: Measurement load cases according to IEC/TS 61400-13 [33].	34
Table 5-1: Status of IEC standards (publishing date, FDIS=Final draft, CDV=Committee draft for voting, CD= Committee draft, no date= in preparation)	43
Table A-1: Down time and technical availability over 15 years [63].....	60
Table A-2: Down time and technical availability over rated power for 2007 [63]	61
Table A-3: Technical availability of various wind turbines [63].....	62
Table A-4: Overview of data for gearbox failures in Sweden from 1997 to 2004 [49]	67
Table A-5: Type of gearbox failure [49].....	67

1. Introduction

1.1 *PROTEST* project

High reliability of wind turbines and their components is one of the pre-requisites for an economic exploitation of wind farms. For offshore wind farms under harsh conditions, the demand for reliable turbines is even more relevant since the costs for repair and replacement are very high. Unfortunately, present day wind turbines still show failure rates between 2 to 5 failures per year that need visits from technicians (derived from i.e. [4], [12], [15]). Although electrical components and control systems fail more often, the costs related to repair of failed mechanical systems (drive train, pitch and yaw systems and bearings) are dominating the O&M costs and downtime. Appendix A gives a detailed overview regarding the component failures and O&M costs.

In-depth studies, e.g. [59] and discussions with turbine manufacturers, component suppliers, and certification bodies [13] revealed that one of the major causes of failures of mechanical systems is insufficient knowledge of the loads acting on these components. This lack is a result of the shortcomings in load simulation models and in load measurement procedures on the level of the components. Due to the rapid increase of wind turbines in size and power as a response to the market demands, suppliers of components are forced to (1) come up with new designs very often and (2) produce them in large numbers immediately. The time needed to check whether the components are not loaded beyond the load limits used in the design and to improve the design procedures is often not available or transparent to the component supplier. This leads to the unwanted situation that a large number of new turbines are equipped with components that have not really exceeded the prototype phase.

It was also concluded from a.o. [59] and expert discussions [13] that at present, the procedures for designing rotor blades and towers of wind turbines are much more specific than the procedures for designing other mechanical components such as drive trains, pitch and yaw systems, or main bearings. The design procedures for blades and towers are clearly documented in various standards and technical specifications. The reason for having extensive design standards for blades and towers is that these components are critical for safety: failures may lead to unsafe situations and designing safe turbines did have (and should have) the highest priority in the early days of wind energy. Parallel to the development of design standards, the wind energy community has developed advanced design tools and measurement procedures to determine the *global turbine loads* acting on the rotor and the tower. At present however, it is no longer acceptable to focus on safety only and neglect the economic losses. Lacking of clear procedures for designing mechanical components and specifying the loads on these components should no longer be the reason for early failures.

In 2007, ECN (NL) together with Suzlon Energy GmbH (DE), DEWI (DE), Germanischer Lloyd (DE), Hansen Transmissions International (BE), University of Stuttgart (DE), and CRES (GR) decided to define the **PROTEST** project (*PROcedures for TESTING and measuring wind energy systems*) within the FP7 framework of the EU. The PROTEST project in fact is a pre-normative project that should result in uniform procedures to better specify and verify the *local component loads* acting on mechanical systems in wind turbines. The local component loads should be specified at the interfaces of the components. The relationship between *global turbine loads* acting on the rotor and tower and *local component loads* action on the interface of components is explained in Figure 1.1.

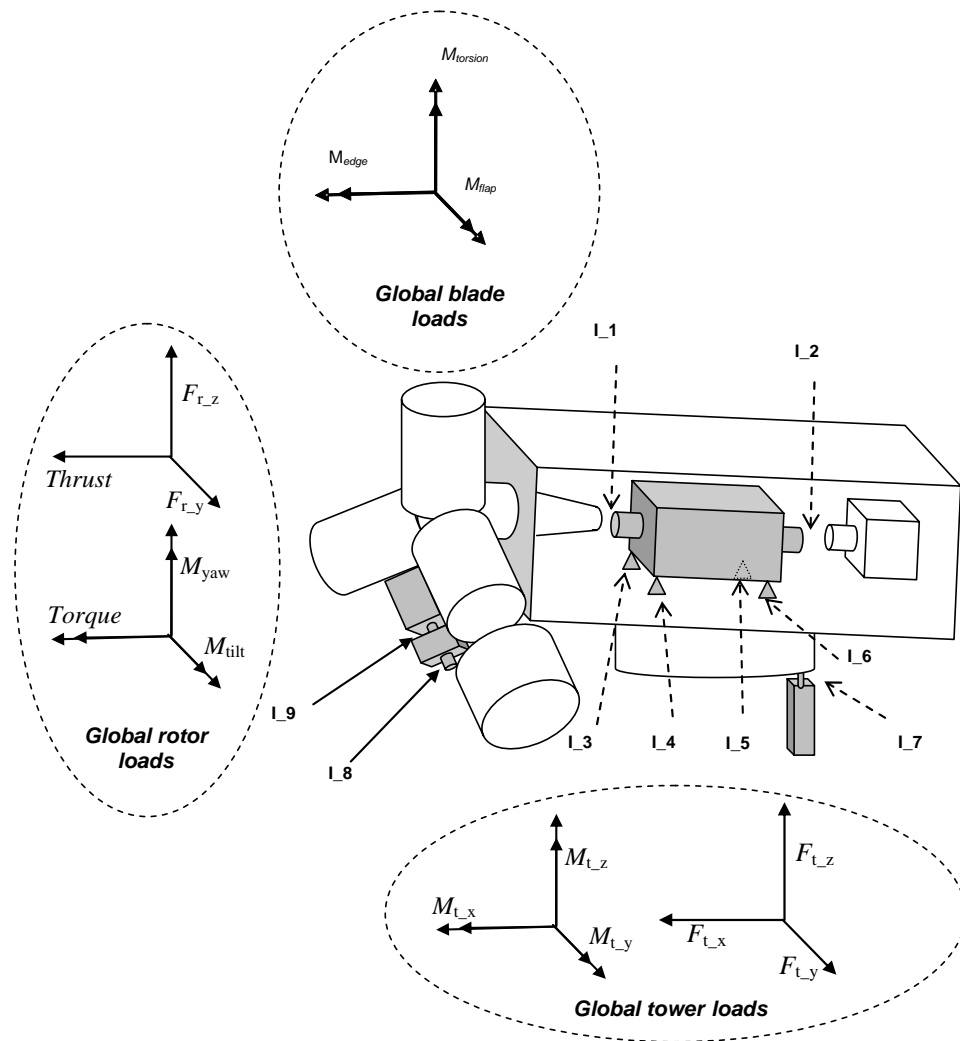

Figure 1.1: Schematic presentation of transforming "global turbine loads" to "local components loads" at nine interfaces, (gearbox, pitch system and yaw system)

The term "loads" should be considered broadly in this respect. It comprises not only forces and moments, but also all other phenomena that may lead to degradation of the components such as accelerations, displacements, frequency of occurrence, time at level, or temperatures. Within the PROTEST project the components drive train, pitch system and yaw system have been selected for detailed investigation.

The uniform procedures to better specify and verify the local component loads should include:

- (1) A method to unambiguously specify the loads at the interfaces where the component can be "isolated" from the entire wind turbine structure, and
- (2) A recommended practice to assess the actual occurring loads by means of prototype measurements.

The following questions will be answered:

- How should the loads at the interfaces be derived from the global turbine loads?
- Which design load cases should be considered and measured and are relevant for the different components?
- Which signals should be measured during prototype testing (including sample frequency, accuracy, duration)?

- How should the loads at the interfaces be reported and communicated between turbine manufacturer and component supplier?
- How can design loads be compared with measured loads?
- Are the current practices of evaluating the experimental data in relation to their use for model tuning accurate?
- Do the assumptions in the model input yield to uncertainties which are higher than the ones achieved during the load measurements?
- What are the criteria to assess whether the measured loads are more benign than the calculated loads?
- Are the current practices of assessing the measured loads and the data post processing results adequate?

To develop the procedures and to carry out the work within the PROTEST project, both analytical work and experimental work are foreseen. The analytical work is needed to determine the relevant load cases and to develop procedures to derive local component loads from global turbine loads during the design. The experimental work is needed to develop and verify new procedures for prototype measurements. In total nine work packages are foreseen.

1. State of the art report: An inventory will be made of the present day practice on turbine and component design and testing, including ongoing standardisation work and identification of areas for improvement.
2. Load cases and design drivers: For the selected components, it will be determined which load cases and design driving factors (external, operational or design inherent) should be considered
3. Loads at interfaces: For the selected components, it will be specified how the loads at the design points should be documented with the aim of being a meaningful improvement over the current state-of-the-art (reporting format, time series incl. synchronisation and minimum frequencies, statistics, spectra, time-at-level, etc.)
4. Prototype measurements definition: For each component, a recommended measurement campaign will be defined taking into account the following aspects: load cases, signals (torques, bending moments, forces, motions, accelerations, and decelerations), sensors, measurement frequencies, processing, uncertainties and inherent scatter, reporting.

Experimental verification is planned for the three components involved in the project. This work is defined in the Work Packages 5, 6, and 7.

5. Drive train: Suzlon S82 turbine in India with gearbox of Hansen Transmissions.
6. Pitch system: Nordex N80 turbine owned and operated by ECN at flat terrain.
7. Yaw system and complex terrain effects: NM 750 turbine in Greece in complex terrain.

In these three case studies, the initial procedures developed in task 1 through 4 will be applied. The initial design loads at the interfaces will be determined with state-of-the-art design methods and the measurement campaign will be executed to verify these design loads.

8. Evaluation and reporting: Based on the results of the design study and the measurement results, the procedures of task 2, 3, and 4 will be evaluated and if necessary improved.
9. Management, Dissemination and Exploitation

As mentioned previously, The PROTEST project in fact is a pre-normative project that should result in uniform procedures to better specify and verify the local component loads acting on mechanical systems in wind turbines. Ultimately, the procedures generated in this project should be brought at the same level as the state-of-the-art procedures for designing rotor blades and towers. If appropriate, the results of this project will be submitted to the (international) standardisation committees.

The project runs from March 2008 until mid 2010.

1.2 Scope of the Report

This state of the art report is the result of work package 1 of the PROTEST project. First of all, the report describes the state of the art of component design (Chapter 2), the state of the art to execute measurement campaigns of prototypes (Chapter 3), and the approaches that are being used to compare the measured loads with the design loads (Chapter 4). Attention is given to the relevance of the different load cases for the different component designs, the role of standards for design and prototype measurements, and the use of simulation tools to determine global and local loads.

Furthermore, in these chapters attention is paid to the use of measured data to validate the design models and to load cases that occur seldom. Such load cases may lead to extreme loads but can hardly be measured.

In the first four chapters, the focus is on design and development of components and feeding back measured data to improve the design. The next stage in the development of a wind turbine is the certification. In Chapter 5, the use of design and measured loads during the certification process is discussed. Ultimately, the strength of the components should be sufficient to withstand the occurring loads. The chapter pays attention to the assessment of load sets that are constructed from design loads in combination with measured loads.

This state of the art report concludes with proposals to improve the current practices for determining and measuring loads at the interfaces (Chapter 6 and 7). In fact, these proposals can be regarded as a further refinement of the initial work plan of the PROTEST project.

In Appendix A, the relevance of reducing the failure rates of components will be demonstrated. An overview is given of the failure of mechanical components together with their consequences, both in terms of downtime and costs.

2. State-of-the-art design approach

2.1 Recent developments in wind turbine technology

2.1.1 Increase in size and power

The wind energy industry has been rapidly growing for years, both in the amount of installed capacity (see Figure 2.1 through Figure 2.4), and in the size of turbines (see Figure 2.4). In early 2008 the Global Wind Energy Council released statistics showing that over 20,000 MW of wind power was installed in 2007, led by the US, China and Spain, bringing world-wide installed capacity to 94,112 MW. This is an increase of 31% compared with the 2006 market, and represents an overall increase in global installed capacity of about 27%. Over the last decade the wind capacity grew with average growth rates well above 20%. In 2007 wind capacity grew more in Europe than any other power-generating technology [47] reaching a level of 56,535 MW. Total wind power capacity installed by the end of 2007 will avoid about 90 million tonnes of CO₂ annually and produce 119 Terawatt hours in an average wind year, equal to 3.7% of EU power demand. In 2000, less than 0.9% of EU electricity demand was met by wind power.

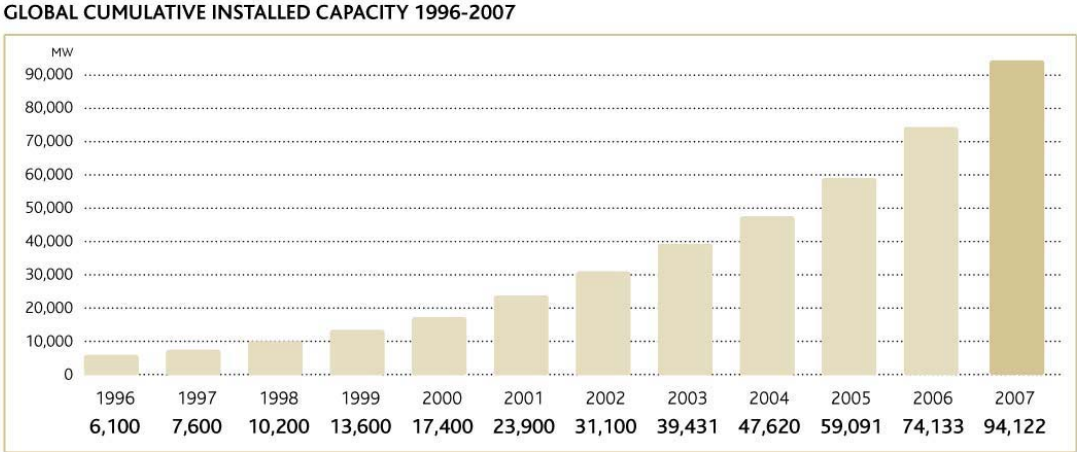

Figure 2.1: Global cumulative installed capacity 1996 – 2007 [20]

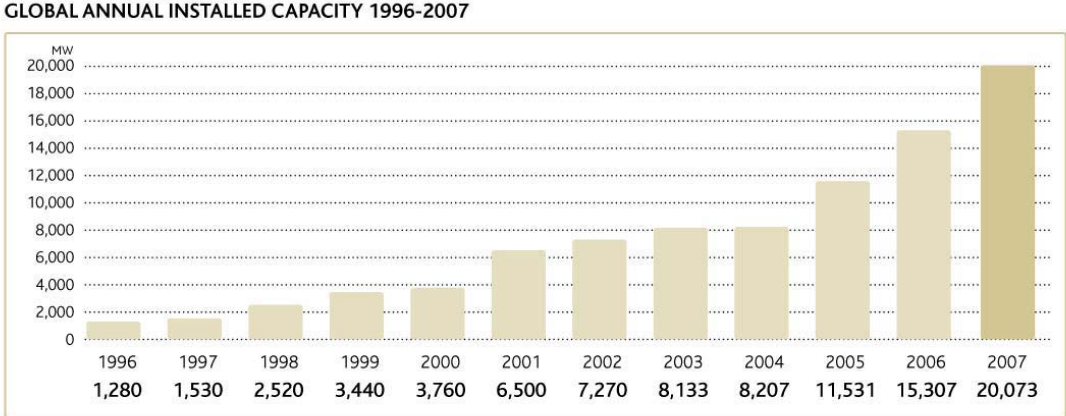

Figure 2.2: Global annual installed capacity 1996 – 2007 [20]

ANNUAL INSTALLED CAPACITY BY REGION 2003-2007

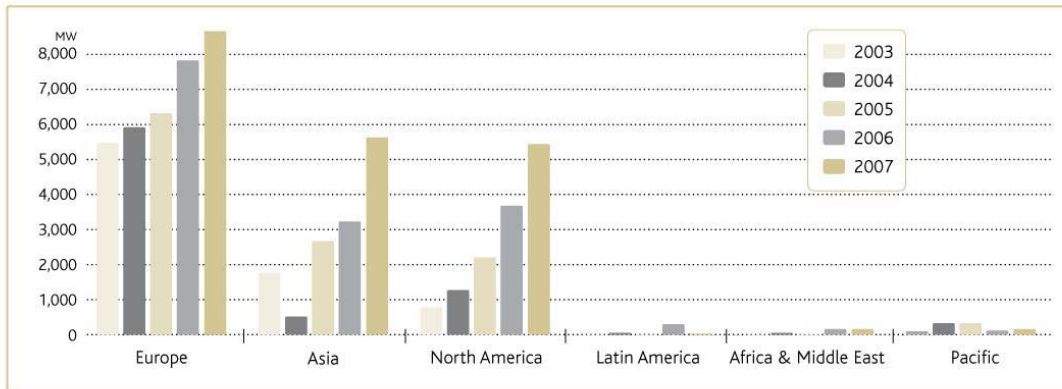

Figure 2.3: Annual installed capacity by region 2003 – 2007 [20]

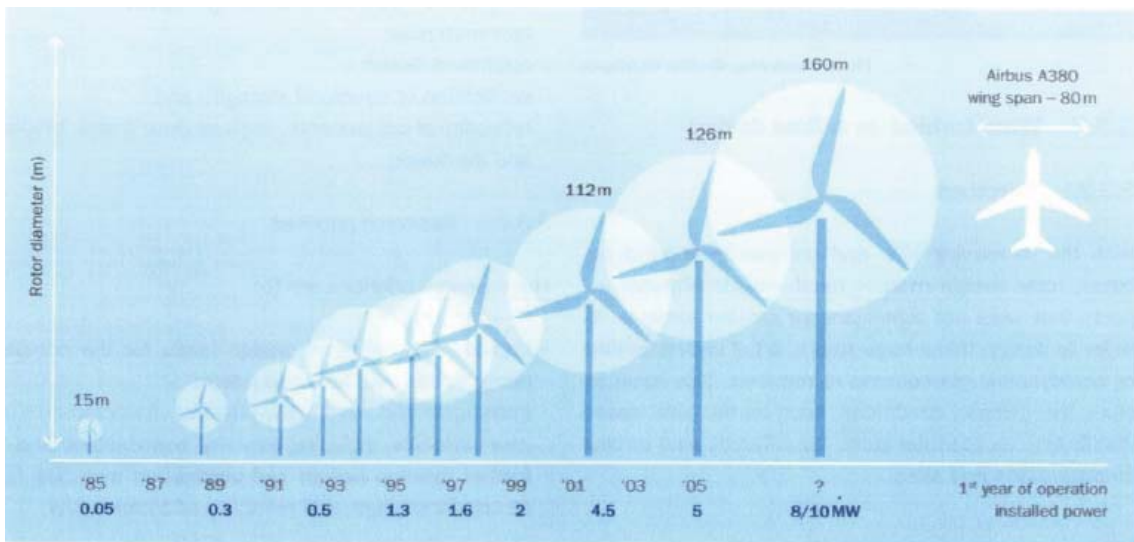

Figure 2.4: Development of the size of wind turbines [54]

In 2007, several turbines are being operated which have a rated capacity of 5 MW or more and a rotor diameter above 110 m. Fast up-scaling requires innovative designs and manufacturing procedures. A strong demand for up-scaling comes from the market to erect wind turbines offshore. Larger turbines require fewer foundations, less handling, and less crane costs during installation and operation per MW.

By 2007, the industry had developed 25 offshore projects, many of them large-scale and fully commercial, with a total capacity of around 1100 MW in five countries. In terms of electricity production, at the end of 2006, offshore wind farms represented 1.8% of the total installed wind power capacity, but generated 3.3% of electricity from wind energy. An overview of the developments in the different countries is given in Table 2-1 [5].

	Installed MW 2006	Accu. MW 2006	Installed MW 2007	Accu. MW 2007
Country				
Denmark	0	397.9	0	397.9
Ireland	0	25	0	25
The Netherlands	108	126.8	0	126.8
Sweden	0	23.3	110	133.3
UK	90	304	90	394
Total capacity - World	198	877	200	1077

Source: BTM Consult ApS - March 2008

Table 2-1: Overview of the installed offshore wind power capacity (end of 2007)

In 2007 more than 90% of the new capacity has been supplied by less than 10 large manufactures, shown in Figure 2.5.

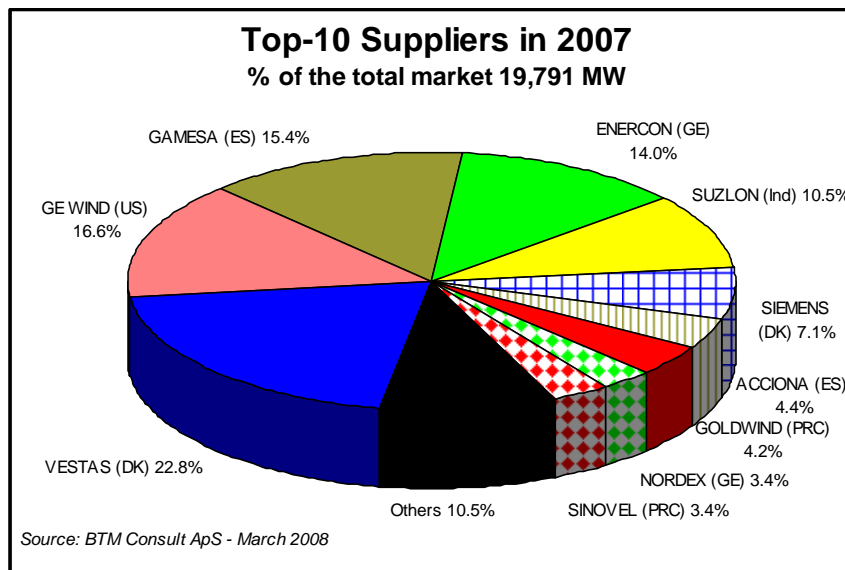

Figure 2.5: Top-10 suppliers in 2007

As mentioned earlier, innovative designs and concepts are needed to develop reliable and large turbines for on- and offshore applications. An overview of the present technology for mainly the mechanical components in wind turbines and relevant for this PROTEST project will be discussed in the following sections. Pros and cons of the different concepts will be mentioned. However it is not the intention of the authors to assess or rank the concepts. The actual benefits of the various concepts strongly depend on the detailed design and engineering, and the quality of manufacturing and maintenance.

2.1.2 Drive train concepts

Roughly, five drive train concepts can be distinguished.

Figure 2.6 gives an overview about these concepts, which are presented below.

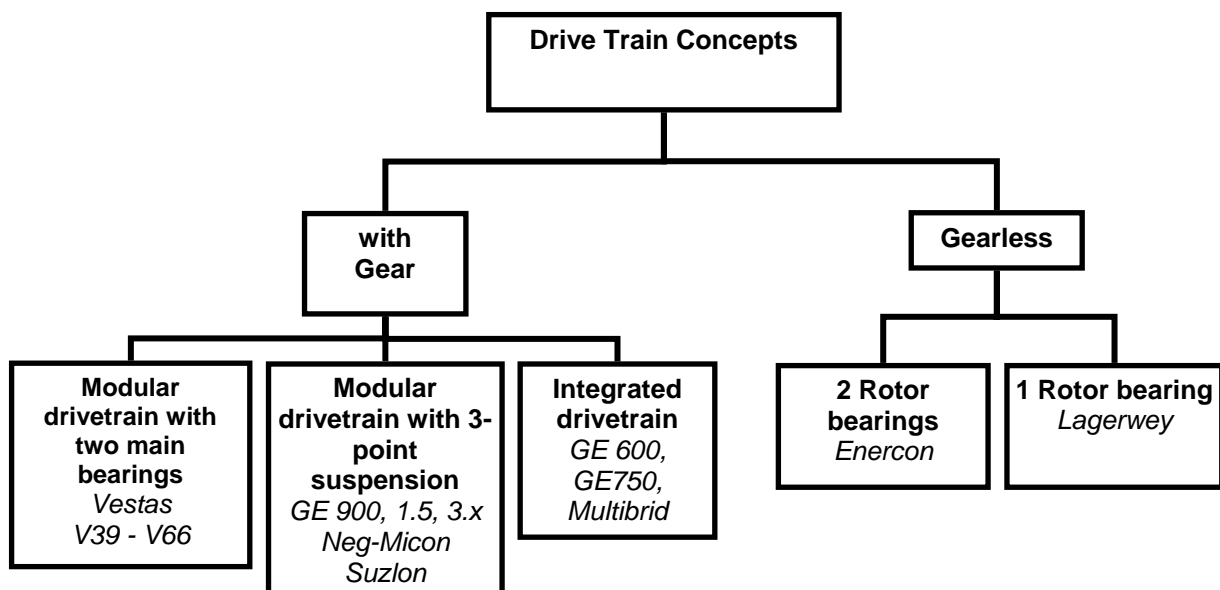

Figure 2.6: Overview of common drive train concepts

1. *Modular drivetrain with two main bearings*
 - Gamesa G8X-2MW
 - REpower 5M/6M
 - Vestas (V39 - V80, V90-2MW)



Figure 2.7: Modular drive train with two main bearings using the example of REpower 5M (Source REpower)

The concept shown in Figure 2.7 is well known and can be easily up-scaled with more or less “off the shelf” components. However, the low speed stage of the gearbox is a “wind turbine specific” item. For wind turbines less than or equal to about 2.1MW (e.g. Suzlon S88), one planetary stage and two parallel stages are being used; for larger turbines, two planetary stages in combination with one parallel stage are being used. The main advantage of this concept is the fact that the bending moments are not transferred to the gearbox. Moreover, the modular design is an advantage with respect to maintainability and offshore applications.

2. *Modular drivetrain with 3-point suspension*
 - Bard
 - GE-Wind (2.x)
 - Nordex
 - REpower (up to 3.xM)
 - Siemens (former Bonus)
 - Suzlon

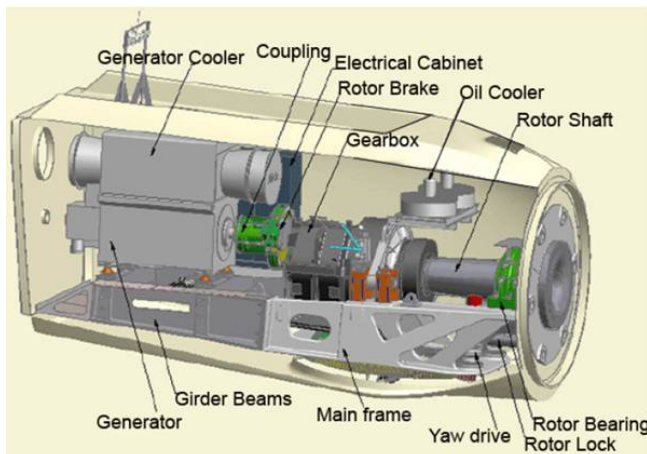

Figure 2.8: Modular drive train with 3-point suspension using the example of Suzlon S88 (Source: Suzlon)

Similar to the previous concept, however, in this concept as shown in Figure 2.8 only one main bearing is used which leads to a more simple design. But therefore the loading of the gearbox is harsher because the bending loads are induced to the gearbox housing.

3. *A: Integrated drivetrain*
 - Ecotechnia
 - Nordic Wind Power
 - Vestas V90-3MW

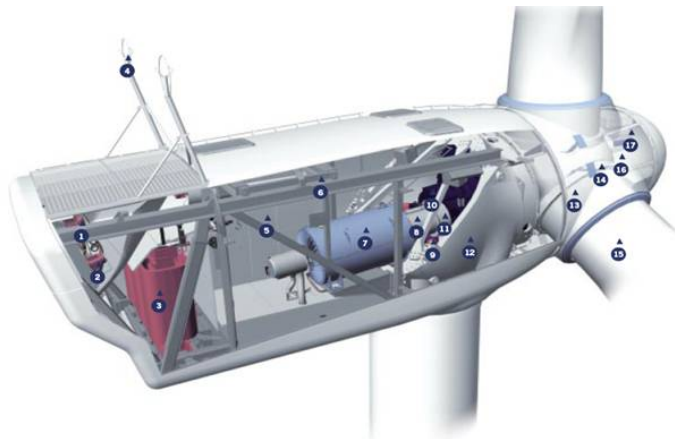

Figure 2.9: Integrated drivetrain using the example of Vestas V90-3MW (Source: Vestas)

In this concept, as shown in Figure 2.9 no conventional rotor shaft is used. A load flow optimised bed plate transfers the rotor loads to the tower so that the gearbox is only loaded by rotor torque. The main advantage of this concept is the weight reduction of the tower top mass.

3. *B: Hybrid Design (one stage planetary gearbox, Permanent Magnet Generator at intermediate speed)*
 - Gamesa G10X (Currently under development)
 - Multibrid M5000 (5MW rated power, gearbox ratio: $i = 1:9.92$)
 - WinWind WWD-1 (1MW), WWD-3 (3MW)

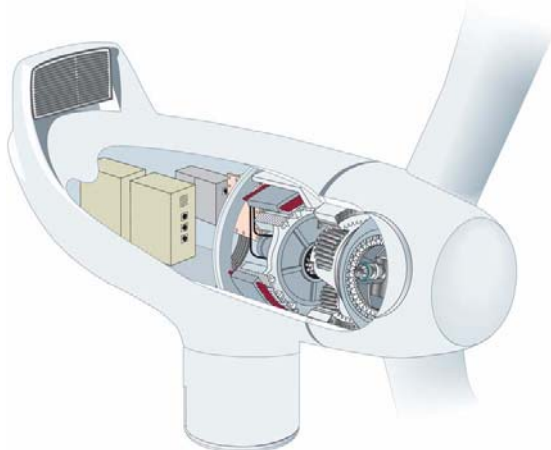

Figure 2.10: WinWind WWD-1 with hybrid design (Source: WinWind)

The hybrid design, as shown in Figure 2.10 offers the possibility to design a light-weight, compact and integrated drive train. The gearbox does not include a high speed shaft (like in concept 1 and 2) which prevents possible failure on high speed bearings. In this hybrid design, bending loads are transferred through the gearbox housing, similar to concept 1. An integrated design is not always an advantage w.r.t. replacement of components. Since the integrated design combines two innovative products (gearbox and permanent magnet generator at medium speed) which are not “off the shelf”, two separate developments should be done “in house” for few applications only. This will only pay back at larger quantities.

4. *Direct drive, synchronous generator with permanently excited rotor*
 - Directwind
 - Enercon
 - Mtorres



Figure 2.11: Enercon E82 with direct drive, synchronous generator, permanently excited rotor (Source: Enercon)

This direct drive concept, as shown in Figure 2.11 uses a highly integrated design without a gearbox. Therefore a low speed generator needs to be used in direct drive turbines. With the increasing turbine size and power this leads to lower rotor speeds which results in more generator poles and a larger diameter. Enercon solved this by building its new generator in sections. Upscaling has a tendency to become very heavy (Enercon). Mtorres shows that other, more compact building forms are possible.

5. *Direct drive, synchronous generator with permanent magnet generator*
 - Darwind
 - Goldwind (partial)
 - ScanWind
 - Vensys

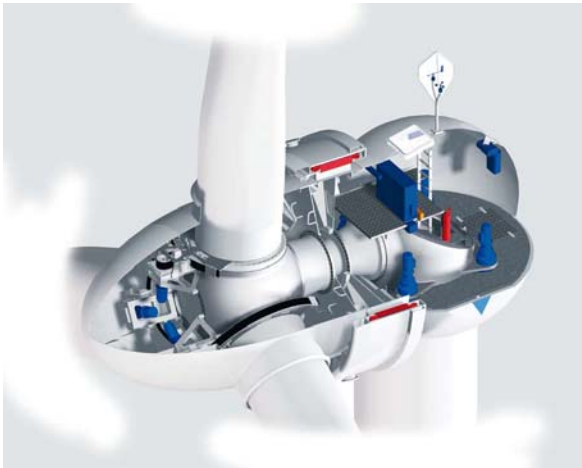

Figure 2.12: Vensys V77, direct drive, synchronous generator, permanent magnet generator (Source: Vensys)

This concept, as shown in Figure 2.12 has some promising features. Powering of the rotor is not needed which leads to a simple design without carbon brushes, and less maintenance is expected. In practice, due to the slightly better efficiency compared to permanently excited generators, more compact and light-weight generator designs (assuming theoretical scaling rules) can be achieved. On the other hand, it may lead to more expensive generators.

The turbine concepts that include gearboxes are of special importance within the PROTEST project. From various studies [12], [24], [56] it is concluded that the electrical sub assemblies in general have a higher failure frequency than the mechanical components. In Appendix A, a detailed evaluation of component failures and associated O&M costs is shown. However, because the downtime and repair costs are typically higher for mechanical components than for electrical components, the perception of failure rates may differ from the actual values: e.g. larger downtime and repair costs of gearbox problems compared to failures of electronic components during the past years have created the perception of higher failure rates of gearboxes. As a consequence, this has led to many research activities to improve the reliability of gearboxes.

Many attempts have been taken by the industry and R&D institutes to improve the reliability of gearboxes and the most relevant ones are mentioned below.

1. Condition Monitoring

In Europe, investigations have been done to improve the reliability of gearboxes by making more use of condition monitoring techniques, for example the EU project CONMOW [59]. The project showed that presently available drive train monitoring systems operate reliably over a longer period. It was demonstrated that these systems are able to detect (1) component errors at an early stage, and (2) off-design conditions such as shaft misalignment. An assessment whether the measurements exceeded critical levels and a prognosis of the remaining life could not be made due to insufficient knowledge of the degradation. In fact a large number of failures need to be observed first before the prognoses of degradation can be made for future failures. The overall conclusion was that condition monitoring systems are able to mitigate the consequences of damage, but do not reduce the number of failures. It was concluded that the reliability of gearboxes can only be improved if the gearboxes are designed to withstand the load spectra that actually occur. This means that, on the one hand, the resistance of the gearboxes to withstand the loads should be adequate (a.o. detailed design of gear wheels and housing, manufacturing procedures, design and selection of bearings, selection of lubrication, cooling, and filtration); on the other hand the methods to define the loads acting on the drive trains should be improved.

2. Failure analyses and gearbox measurements

In the US, NREL has made a commitment to address gearbox reliability as a major part of its R&D agenda, and plans to engage a wide range of stakeholders including researchers, consultants, bearing manufacturers, gearbox manufacturers, wind turbine manufactures and wind turbine owners and operators to form a Gearbox Reliability Collaborative (GRC) [42]. This long term R&D project has not yet firm conclusions about the nature of gearbox failures but some reasonable observations have been made to help narrow the course and scope of the project.

1. Most of the problems with the current fleet of wind turbine gearboxes are generic in nature, meaning that the problems are not specific to a single gear manufacturer or turbine model.
2. The majority of gearbox failures suggest that poor adherence to accepted gear industry practices is not the primary source of failures. The project has the aim to identify and correct deficiencies in the design process that may be diminishing the life of the fleet.
3. Most gearbox failures do not begin as gear failures or gear tooth design deficiencies. The observed failures appear to initiate at several specific bearing locations under certain applications, which may later advance into the gear teeth as bearing debris and excess clearances cause surface wear and misalignments.
4. The majority of wind turbine gearbox failures appear to initiate in the bearings. These failures are occurring in spite of the fact that most gearboxes have been designed and developed using the best bearing-design practices available.

The GRC has planned to carry out detailed load simulations and to verify these loads by means of measurements, both at test rig (Dynamometer Testing) as well as on a fully instrumented wind turbine prototype. The measurements should also reveal the loads inside the gearbox, e.g. on gear wheels and bearings.

3. Improved design software

Improved design practices for drive trains are being developed by making use of multi body simulation tools [3], [26], [46], [53] and taking into account the flexibility of the gearboxes and their housings. In today's practise, wind turbine design and analysis tools had a focus on aerodynamics and aero elasticity. The gearbox and drive trains are modelled as one single torsional spring with a fixed gear ratio, a mass moment of inertia, a spring constant, and a (usually estimated) damping coefficient. At present it is recognised that more degrees of freedom are needed to better understand the dynamics of gearboxes. Unfortunately, no public information has been found on the validation of these more detailed modelling approaches, e.g. by comparing measurements with the simulations. So the adequacy of such detailed models can presently not be assessed.

4. International working groups and standardisation committees

Since the drive train failures started to occur over a large population of wind turbines in the 1990's, the wind energy community has joined forces to better understand the causes of failure and to develop uniform approaches to design gearboxes and to select bearings. This has lead among others to draft IEC standards [7], [32]. The international approach has lead a.o. to a more complete inventory of relevant load cases which should lead to a better understanding of the loads acting on gearwheels and should finally result in fewer failures of the teeth and gearwheels. However, the weakest spot in the gearbox design now seems to be the design and selection of bearings. Concerns have been raised about the bearing type selection, the bearing life calculations, the lubrication, the bearing support rigidity, the load specification, the testing regime, etc. [3] [21], [42]. It is under investigation, whether the dynamic load rating and rating of life of roller bearings, as being used in most branches of industry, is adequate for wind turbine applications.

2.1.3 Pitch system

The aerodynamic power control is based either on decreasing the angle of attack in pitch to feather machines or by increasing the angle of attack into the stall region. In case of a pitch to feather machine one may combine this with a constant or a variable speed generator while almost all pitch controlled turbines employ variable speed. A stall machine may be a constant speed fixed pitch machine (classical Danish concept), constant speed pitch to stall (active stall) or variable rotor speed combined with fixed pitch. The latter concept is not very common. The variable speed concept is superior with respect to the grid coupling. With increasing wind penetration and with concentrated wind energy production on the offshore locations the grid requirements will increase and variable speed designs will benefit by this.

The power control concept of the design cannot be isolated from the protection philosophy and from the start-up and shut-down procedures. The last decade has seen a change from blade tips brakes with mechanical brakes towards individual full span blade pitch as a brake system. Mechanical brakes were placed at the high speed shaft because of cost reasons. Loading of the gearbox was a major point of concern. The tip brakes were replaced due to the blade structure and length, and because of reliability issues. By having individual blade pitch, the requirement of having two mutually independent protection systems is satisfied. Thus, the system for power control is combined with aerodynamic braking.

Presently, most turbines in the multi-megawatt class are equipped with variable speed and pitch control. Pitch control can either be done by means of hydraulic pitch cylinders or by electrical motors. More and more, the option of individual pitch control is being investigated by the leading manufacturers to optimise power output and to reduce the mechanical fatigue loads. However, to reduce the mechanical loads by means of pitch control it is necessary to obtain feedback from the loads in the blades. At present, the measurement techniques are not robust enough that they can be incorporated into the control loop reliably for a long period of time.

From publicly available data on failures and maintenance of wind turbines (e.g. [12], [56] and [63]) it can be concluded that the failure behaviour of pitch systems (number of failures and their resulting downtime and repair costs) is not the real cost driver for maintenance and repair. However there is a strong need to better understand the loads and dynamic behaviour of the pitch system for new and large turbine designs. For instance, larger wind turbines require larger pitch bearings which are relatively less rigid and thus more sensitive to deformations. To determine the lifetime of pitch systems it is necessary to understand the loads and deformations and their influence on friction and wear of the

pitch system. If in the future load measurements are going to be incorporated in the pitch control loop, the number of pitch actions per blade and the pitch speed will probably increase. Under these circumstances the need to understand the loads on and wear of pitch systems is even higher. A first attempt to better understand the load pattern in the different components of a pitch system is presented in [40]. Taking into account the different mass moments of inertia as well as friction properties result into more realistic loads for the whole turbine.

2.1.4 Yaw system

Similar to the pitch system, the yaw system is not a cost driver for the maintenance costs of wind turbines. However, a good understanding of the mechanical loads acting on the yaw system is needed to optimise the design of new turbines.

The concept of passive yawing has been an option for smaller wind turbines. The disadvantage of this concept is that it cannot control the nacelle during off-design conditions and that in case of extreme changes in wind direction, the turbines may continue running downwind instead of upwind (or vice versa). For larger turbines, the use of the active yawing concept is common practice. Several (typically 4 to 8) yaw drives keep the rotor perpendicular to the oncoming wind. Some concepts allow the nacelle to yaw passively in case of small changes in wind directions. Only in case of extreme wind direction changes, in cases of low wind speeds, or during stand still, the yaw system is activated. A disadvantage of this concept is that passive yawing may lead to unwanted loading of the yaw drive and damage to the gearbox. Therefore, more and more turbines are equipped with yaw brakes to avoid passive yawing. This protects the yaw drives from high cycle fatigue due to turbulence induced yaw moments. The yaw brakes can be released during the yaw action itself. The most common concept is that the installed capacity of the yaw drives is sufficient to keep the yaw brakes closed during yaw manoeuvres.

2.2 Determination of design load cases

Design load cases (DLC's) for wind turbines are the combination of the design situations of a wind turbine (both operational modes and event-driven modes) with wind conditions (gusts) and other external conditions. (e.g. grid failures and lightning). Within the scope of this report, the following wind energy standards and/or guidelines have been considered:

- IEC-61400-1 "Wind turbine generator systems - Part 1: Safety Requirements" [27]
- GL Guidelines for the Certification of Wind Turbines [17]
- IEC-61400-4 "Wind turbine generator systems – Design and specification for gearboxes" [32]

Those are in the following denoted as "the wind energy standards". Nevertheless, also national standards have to be considered for the design of wind turbines which will be put in the corresponding countries. Those are for example:

- DiBT German national standard, e.g. [6]
- DS Danish national standard, e.g. [11]

In IEC-61400-1 and the GL guidelines a minimum set of loads is described that shall be considered for the design calculations of a wind turbine. Additional requirements for gearboxes are described in IEC-61400-4. It should be noticed that in practice these wind energy standards are in certain cases used in connection with more detailed design standards. A good illustration for this is given in the wind energy newsletter of GL [21] where the interplay between IEC61400-4 and standards such as ISO 6336 (calculation of load capacity of spur and helical gears) and ISO 281 (Rolling bearings – dynamic load ratings and rating life) is presented and it is shown that the wind energy standards are not used instead of these detailed standards. On the contrary the wind energy standards:

- specify the internal and external load conditions to be considered (for instance in the IEC61400-1 a minimum set of DLCs is defined, whereas in IEC61400-4 additional DLCs specific for wind turbines gearboxes are defined);

- provide specific requirements with respect to the application of the more detailed standards (e.g. target values for some safety factors);
- provide additional demands for aspects not covered elsewhere.

In the following sections, the DLCs mentioned in the wind turbine standards will be discussed, together with their scope and limitations. During the discussions of the DLCs, the objectives of the PROTEST project will be kept in mind, meaning that the usefulness of the DLCs for the design of the drive train, yaw system, pitch system and other mechanical systems will be assessed.

2.2.1 IEC 61400-1

IEC61400-1 3rd edition 2005-08; "Wind Turbines - Part 1: Design Requirements".

This document specifies essential design requirements to ensure the engineering integrity of wind turbines. As a minimum the design load cases described in section 7.4 of this IEC document shall be considered; see Table 2-2. From this table it is clear that only external loading conditions mainly due to wind or electrical conditions are considered.

In Chapter 9 of this IEC document additional demands are given for the mechanical systems¹, such as gearbox, yaw system, pitch system and rolling bearings. These additional demands mainly consist of references to ISO standards and of specification of safety factors. No additional information to determine the design loads at the interfaces is given in this chapter.

¹ A mechanical system for the purposes of this standard is any system, which does not consist solely of static structural components, or electrical components, but uses or transmits relative motion through the combination of shafts, links, bearings, slides, gears and other devices. Within a wind turbine, these systems may include elements of the drive train such as gearboxes, shafts and couplings, and auxiliary items such as brakes, blade pitch controls, yaw drives. Auxiliary items may be driven by electrical, hydraulic or pneumatic means.

Table 2 – Design load cases

Design situation	DL C	Wind condition	Other conditions	Type of analysis	Partial safety factors
1) Power production	1.1	NTM $V_{in} < V_{hub} < V_{out}$	For extrapolation of extreme events	U	N
	1.2	NTM $V_{in} < V_{hub} < V_{out}$		F	*
	1.3	ETM $V_{in} < V_{hub} < V_{out}$		U	N
	1.4	ECD $V_{hub} = V_r - 2$ m/s, V_r , $V_r + 2$ m/s		U	N
	1.5	EWS $V_{in} < V_{hub} < V_{out}$		U	N
2) Power production plus occurrence of fault	2.1	NTM $V_{in} < V_{hub} < V_{out}$	Control system fault or loss of electrical network	U	N
	2.2	NTM $V_{in} < V_{hub} < V_{out}$	Protection system or preceding internal electrical fault	U	A
	2.3	EOG $V_{hub} = V_r \pm 2$ m/s and V_{out}	External or internal electrical fault including loss of electrical network	U	A
	2.4	NTM $V_{in} < V_{hub} < V_{out}$	Control, protection, or electrical system faults including loss of electrical network	F	*
3) Start up	3.1	NWP $V_{in} < V_{hub} < V_{out}$		F	*
	3.2	EOG $V_{hub} = V_{in}$, $V_r \pm 2$ m/s and V_{out}		U	N
	3.3	EDC $V_{hub} = V_{in}$, $V_r \pm 2$ m/s and V_{out}		U	N
4) Normal shut down	4.1	NWP $V_{in} < V_{hub} < V_{out}$		F	*
	4.2	EOG $V_{hub} = V_r \pm 2$ m/s and V_{out}		U	N
5) Emergency shut down	5.1	NTM $V_{hub} = V_r \pm 2$ m/s and V_{out}		U	N
6) Parked (standing still or idling)	6.1	EWM 50-year recurrence period		U	N
	6.2	EWM 50-year recurrence period	Loss of electrical network connection	U	A
	6.3	EWM 1-year recurrence period	Extreme yaw misalignment	U	N
	6.4	NTM $V_{hub} < 0,7 V_{ref}$		F	*
7) Parked and fault conditions	7.1	EWM 1-year recurrence period		U	A
8) Transport, assembly, maintenance and repair	8.1	NTM V_{maint} to be stated by the manufacturer		U	T
	8.2	EWM 1-year recurrence period		U	A

The following abbreviations are used in Table 2:

DLC	Design load case
ECD	Extreme coherent gust with direction change (see 6.3.2.5)
EDC	Extreme direction change (see 6.3.2.4)
EOG	Extreme operating gust (see 6.3.2.2)
EWM	Extreme wind speed model (see 6.3.2.1)
EWS	Extreme wind shear (see 6.3.2.6)
NTM	Normal turbulence model (see 6.3.1.3)
ETM	Extreme turbulence model (see 6.3.2.3)
NWP	Normal wind profile model (see 6.3.1.2)
$V_r \pm 2$ m/s	Sensitivity to all wind speeds in the range shall be analysed
F	Fatigue (see 7.6.3)
U	Ultimate strength (see 7.6.2)
N	Normal
A	Abnormal
T	Transport and erection
*	Partial safety for fatigue (see 7.6.3)

Table 2-2: Design load cases for wind turbines specified in IEC 61400-1

2.2.2 GL guidelines

IV Rules and Guidelines Industrial Services - Part 1: "Guidelines for the certification of Wind Turbines, Edition 2003, Germanischer Lloyd"

Similar to IEC 61400-1 requirements for determining the load cases to be considered are given in Chapter 4 of this GL guideline. The minimum number of DLCs can be found in section 4.3 of the GL guidelines [19] (table is not copied into this document). Comparing the DLCs of both guidelines (GL and IEC 61400-1) it can be concluded that design situations do agree, although in the GL guidelines for some design situations a number of additional DLC's have been specified. Furthermore it shall be mentioned that the IEC61400-1 in it's 3rd edition applies a turbulent wind field for a number of transient DLCs where the GL Guideline applies a steady wind field.

In part 2 "Guidelines for the certification of Offshore Wind Turbines, Edition 2003", also the wave loading is considered, resulting in more extensive list of DLC's.

In Chapter 7 of the GL guideline Part 1 additional demands are given for machinery components, such as blade pitch system, bearings, gearboxes, yaw system etc. Similar to IEC 61400-1 no additional DLCs are specified. For some components it is stated in general terms that some loads (mostly caused by the geometry) should be included. For the generator bearing and the gearbox bearing at the outgoing high speed shaft loads due to misalignment between gearbox and generator should be considered. For the gearbox it is mentioned that depending on the drive train concept additional loads may be introduced at the gearbox input and output shaft. However in both cases no further details are given.

2.2.3 IEC 61400-4

JWG_N75 – 2nd working draft of IEC 61400-4 "Design requirements for Wind Turbine Gearboxes".

As part of the design process of a drive train the characteristics which can influence the correct operation should be defined. Events leading to these effects can then be derived from load simulations. Hence it may be required to define specific DLC's in addition to IEC 61400-1 (or the GL guidelines Part 1) which shall be considered in the design of a wind turbine. In IEC 61400-4 it is stated that the following examples can be used as a starting point to define these additional DLC's:

- design load cases resulting in axial motions at low loads
- design load cases including generator switch operations, for example for 2-speed generators
- design load cases resulting in torque reversals
- design load cases resulting in acceleration and deceleration of the drivetrain (e.g., high speed side caused by brake events or grid loss)
- design load cases at reduced rated power (e.g. noise reduction operation, block control operation) resulting in torque reversals
- design load cases at wind speeds below cut-in (e.g., idling, pendulum and braked)
- design load cases caused by asymmetric loads from mechanical brake (normal or fault).
- Design load cases resulting from actions at periodic maintenance (e.g., emergency stop system tests)

Hence the IEC 61400-4 provides a good starting point, but no specific DLCs are defined.

From the first review of load cases specified by the IEC standards and GL guidelines, it cannot be concluded if those are specific enough to determine the design loads for mechanical components; this is also part of the PROTEST project. A first conclusion is that although the standards and guidelines give some directions for the component designers to extend the list with DLC's, a more detailed and unambiguous list with DLC's would be preferred. It should include at least the minimum number of occurrences or the duration of the DLC's, a detailed description of operational modes and the external conditions.

2.3 Simulation of overall wind turbine loads

2.3.1 Wind turbine design approach

The recent wind turbine design approach is split up into two steps that are defined by different kinds of standards and guidelines. This two step approach is shown in Figure 2.13.

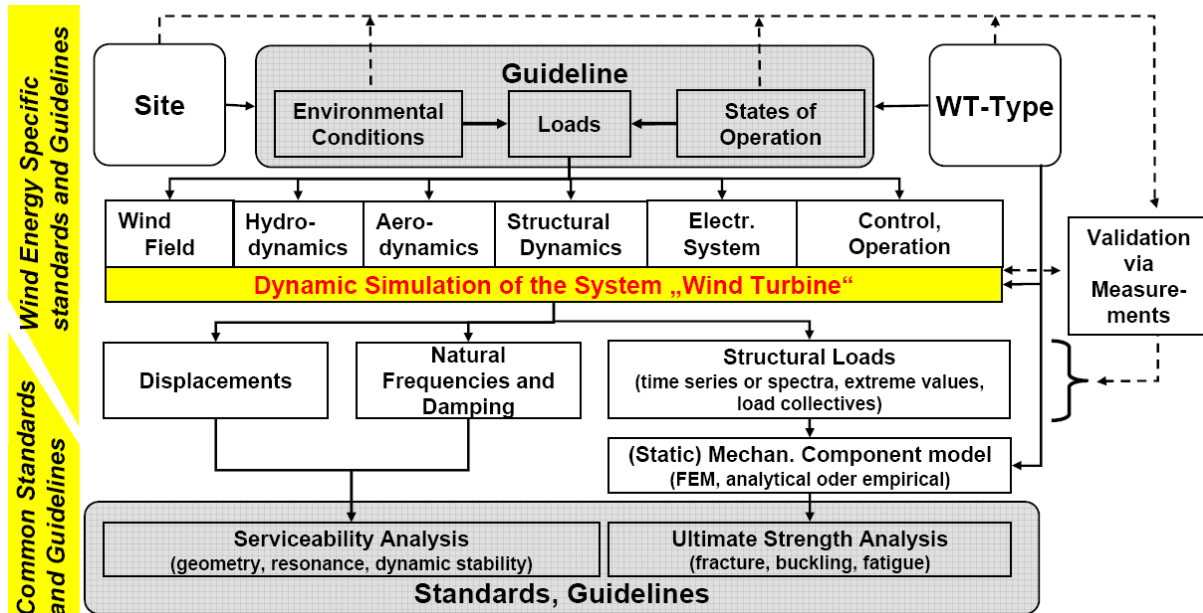

Figure 2.13: Wind turbine design process [16]

In the first step, as shown in Figure 2.13, wind energy specific standards and guidelines define the load cases based on the site and the wind turbine type that have to be analysed in the overall wind turbine load simulation. The loads at interfaces, the global deformations, and the eigenmodes are numerically determined using structural dynamical simulation. Therefore the aerodynamics, hydrodynamics and structural dynamics, as well as the electrical, operational, and control system are usually simulated in one single model within time domain. Since this section describes the “Dynamic simulation of the system wind turbine”, section 2.4 shows how the loads at interfaces are derived from the overall simulations.

In a second step, serviceability analysis and limit state analysis is performed using detailed models of the wind turbine components. This component verification is defined in common standards and guidelines. This approach is introduced in section 2.5.

2.3.2 Simulation tools

Wind turbine loads are simulated with modern dynamic simulation tools. Most of the simulation tools are dedicated programs used solely for simulating wind turbine loads like e.g. BLADED, Flex5, HawC, or FOCUS. Recently, commercial dynamic analysis codes (ADAMS, SAMCEF and SIMPACK) were introduced for wind turbine load simulations. The commercial analysis codes provide advanced models that are more capable of accurately modelling turbine components. Most turbine manufactures still use the first group of simulation codes, i.e. the dedicated wind turbine dynamic simulation codes for load simulations due to familiarity and the high computational speeds. Flex5 and BLADED are currently the industry standards, although many manufacturers have developed their own in-house simulation tools, typically as add-ons or further developments of the FLEX5 code.

The dedicated wind turbine simulation codes use the Blade Element Momentum method (BEM) in order to determine the aerodynamical loads experienced by a wind turbine system. The programs also have the capability to create turbulent wind fields that are used in the subsequent BEM simulation. The BEM method allows for the simplification of the wind turbine aerodynamics by using the non dimensional airfoil lift, drag and moment coefficients and assuming each section of the blade is radially independent. The forces on the blade are determined by the lift and drag created at each section by

the inflow conditions. The torque and thrust is calculated by integrating the lift and drag along the blade section [25]. The loads of the wind turbine system are determined from these loads and the dynamics they create in the wind turbine system.

Several corrections are made after the initial aerodynamical calculations. The Prandtl tip loss factor is used to correct for a finite number of blades that alters the actual wake vortex. The Glauert correction corrects for large axial induction factors. Other corrections can be added to modify the calculated airfoil lift and drag coefficients to handle dynamic wake effects, stall delay and hysteresis.

The BLADED and Flex5 codes take advantage of the modal reduction technique in order to optimize the amount of computer memory and time necessary to run the simulations. The motions of the blades can be simplified to a combination of mode shapes. The mode shapes, used in the code Flex5, are shown in Figure 2.14. The determination of the deflected shape during operation, and the changing loads due to shape changes, can be determined using this method. This allows the simulations to run faster than real time. Programs that do not use modal reduction usually determine the dynamics and deflections using a beam/finite element type blade model. These codes generally need more computational time to run.

A more comprehensive overview of simulation tools can be found in literature [45].

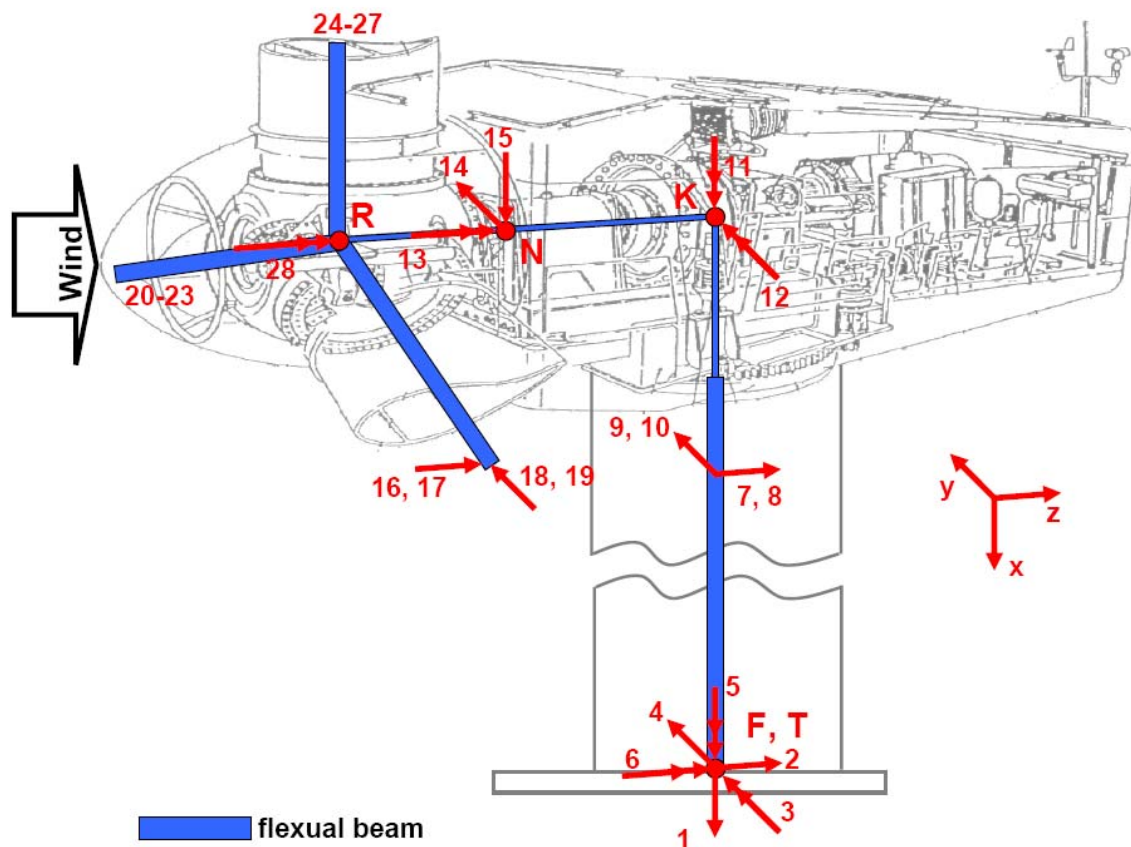

Figure 2.14: Modelling of a wind turbine for aeroelastic simulations using the code Flex5 (Source: Vestas)

2.3.3 Sources for loads

Wind turbine loads are generated by the different conditions [40]:

- Static loads like e.g.:
 - Weight
 - Steady rotation

- Dynamic loads like e.g.:
 - Transients (e.g. start /stop manoeuvres, accelerations, grid connection, grid fault, change in average wind speed)
 - Cyclic /periodic (e.g. wind shear, tower shadow, blade mass)
 - Stochastic (e.g. turbulence)

During operation the turbine will experience many of the preceding load sources simultaneously. A turbine in operation will experience static loads (rotor mass) and the centrifugal forces combined with the blade cyclic loading, tower shadowing and turbulent inflow. Any of the dynamic load sources has the potential to induce a resonance which makes the load amplification from one point to another worse. A difference that should be pointed out is the difference between cyclic loading which might coincide with structural resonance frequencies and transient loads which also excite the components at their natural frequencies, but those do this only during a transient such as no energy is continually fed to these frequencies. A stop event will certainly combine all the above sources. Simulation codes combine all these sources in order to fully model the reactions of the wind turbine system.

The overall dynamic simulation tools allow modelling the incoming wind using various turbulence models. The incoming wind and the turbine control actions create for a matrix of design load cases. One of the standards defining design load cases for a wind turbine is the International Electrical Commission (IEC) 61400-1 'Wind Turbines Part 1: Design Requirements'. (See also Table 2-2) The IEC requirements are applied by most certification bodies.

The IEC design load cases are defined for eight situations [40] (See also Table 2-2):

- Power production under normal conditions
- Power production with a operational fault
- Start up
- Normal shut down
- Emergency stop
- Parked (Rotor stopped or idling)
- Parked with operational fault
- Transport, maintenance and repair

The design load cases are either used to determine fatigue loading of the turbine system or extreme loads for wind turbine design and certification purposes. There is flexibility in the system if an assessment by the wind turbine manufacturer shows that the design load case is not relevant to the specific turbine design. The IEC design load cases are theoretically all-encompassing. Any and all damaging load cases should be covered under the eight categories. For certification purposes, the IEC specified load cases are minimum requirements, but the certification body can be demand additional load relevant DLCs. Other load cases may be determined through simulation of the turbine system.

Simulation cases are generated by using the IEC design load cases. The bulk of the simulations entail the normal power production runs without fault in order to create a database of loads that will allow for the fatigue analysis of the turbine and the extrapolation of extreme loads under normal operation. The IEC requirements state the minimum number of simulation time for each wind category. In addition, a considerable number of load cases with various combinations of operational and external conditions need to be evaluated in the ultimate load analysis.

The fault case analyses are used for determination of extreme loads and also used in the fatigue calculations for the turbine system. The IEC makes assumptions on the number of events that occur during the life of a turbine and these are incorporated into the fatigue reactions, such as the number of stop and start events. Using the basic IEC design load conditions as inputs, the simulation tools can generate loads throughout the turbine system.

2.4 Determination of component design loads and design stresses

The IEC design load cases are supposed to be non-specific, i.e., the designer is expected to find the worst case scenario possible within the design envelope of the turbine model and design load cases and use it as the governing condition to determine the design loads. This 'design load case' will provide the maximum load a component will need to withstand; therefore it can be used to dimension the component for its maximum load. Note that different design load cases need to be used for different components. The direct method, as suggested by the IEC standards, is to derive stress time histories with the superimposed loading of the component. The stress time history can then be used as a single signal for the fatigue and extreme load calculations. However, this implies an 'a priori' knowledge of the component design from which the component reactions can be calculated.

The determination of the design load case for a component entails running many possible fault/wind condition scenarios and searching for the maximum loads at the various components. The matrix of simulations to be run must include various faults (control system faults, loss of grid...) and wind speeds and conditions (gusts, extreme wind speeds...). The methodical process is to run all possible load cases in simulations and search the results for the maximum loads. It is the job of the designer to determine the worst case scenario for the turbine system and analyse the turbine response. The determinations of all possible loadings need to be taken into account when dimensioning the component. Often more than one governing load case is used to dimension a component as different load cases produce different types of loading.

The rotor aerodynamics and system dynamics determine the loading of the turbine system. The rotor input data consists of the geometry, aero-profile data and structural information for the blade. The load summation at the rotor axis (torque) and blade root (thrust) are the loads that determine the reactions throughout the rest of the turbine system.

Behind the rotor (assuming an upwind turbine), the simulation inputs are relatively simple for the standard aeroelastic simulation code.

2.4.1 Drive train design loads

For instance, the standard Flex5 code uses only six parameters to simulate the drive-train: The bending stiffness of the shaft in two directions, the torsional stiffness of the shaft, the shaft length, the mass moment of inertia of the generator at the shaft and the gear ratio of the gear box, along with a generator torque curve. Other simulation codes have a similar limited number of input parameters used to model the drive train. The lack of inputs also limits the amount of output in the drive train area of wind turbine simulation code. A method to overcome the input limitations is the use of dynamic linked libraries (DLL) to introduce more advanced multi-body or similar drive train simulation models. This allows for more advanced modelling of the turbine components with feedback to the main aerodynamic simulation code. This can be done to model the gearbox or other components and return more accurate reactions to the low speed shaft, which in turn affects the rotor.

DLLs work as separated but linked programs that take any number of outputs from the wind turbine simulation code and calculates the drivetrain reaction at every timestep. The multiple DLL outputs can be used to determine power output and be used as feedback to the front end aeroelastic simulation code. With this method the gearbox, drivetrain and generator reactions are fed back into the aeroelastic simulation code. The aeroelastic simulation code can use the inputs, along with the aerodynamical information from the next time step and produce a more accurate simulation.

By either using a DLL or the stand-alone aeroelastic simulation code, the loads on a specific component can be determined. By searching the time history output files, the maximum loading can be determined. Given a load and a designed component, the maximum stress on a component can be determined with either first principles or with the use of the finite element method. In the design phase, the loading can be used to dimension the component. In the verification phase, the designed properties of the component can be used in the dynamic simulation and the reaction verified.

If component design changes modify the reactions of the turbine, the new component design information needs to be included in further simulation runs to verify the design.

By simulating the turbine under the expected environmental conditions, a component fatigue analysis can be undertaken. Again, changes in the turbine design for not meeting the fatigue life criteria will necessitate further simulation runs to verify the new design. All IEC load and design values are covered by various partial safety factors listed in the standard. The partial safety factors are used to account for uncertainty in material knowledge, design, and other unknowns in the design of the turbine. The IEC partial safety factors used for loading are specific to the type of operation (Normal, Abnormal, Transport and Erection).

2.4.2 Pitch system design loads

For the determination of the design loads relevant for the pitch system, the rotor blade root pitch moment and the blade root bending moments are gained from the aeroelastic simulations. To consider the loads which occur during pitch manoeuvres, the pitch actuator is modelled in those codes. The pitch actuator model is dependent on the wind turbine controller and its dynamics influences the blade root loads. The controller can either define the pitch angle or the pitch rate which is then modified by a transfer function in the pitch system model. However, the drive train dynamics of the pitch system is not modelled in detail.

For the determination of the pitch system design loads, combined analytical and empirical methods are used to transfer the blade root loads into the loads relevant for the design of the pitch system. This step is needed because the moments and forces acting on the tothing of the pitch system is highly dependent on the blade bearing friction and bearing deformations like ovalisation, which is again mainly caused by the blade root bending moments in edgewise and flapwise direction. These analytical models are a weak point in the current design process of the pitch system.

2.4.3 Yaw system design loads

In aeroelastic design codes the yaw moment is calculated during aeroelastic simulations of the relevant load cases. Therefore an active yaw system can be taken into account, if applicable. For wind turbines that are equipped with active yaw systems, a yaw manoeuvre can either be predefined during aeroelastic calculations or the control system can be used to specify the yaw angle or the yaw rate. The yaw can be defined as a rigid system that follows the predefined or controller demanded angles or rates. Most yaw systems are equipped with brakes to unload the yaw system when the system is not active. To exclude cycling loads on the tothing, it is common practise to have a constantly acting residual braking moment which leads to a higher static loading during yawing. To take these loads into account the yaw system can also be modelled flexible to consider the yaw system dynamics. The yaw system drive train is usually not considered in this type of simulation.

For the fatigue analysis of the yaw system the load duration distribution (LDD) of the yaw moments derived from the aeroelastic simulations should be considered.

However there are numbers of issues still open for the determination of the loads acting on the yaw system, since the load transfer from the rotor to the tower top (through the yaw system), passes through the drive train and the nacelle, which as already stated are only very rough modelled in the aeroelastic simulation tools.

2.5 Determination of components design strength and of limit state analyses

2.5.1 Component design strength

The entire load spectrum, extreme and fatigue loads, are necessary to fully design any component. The IEC standard states various partial safety factors for different loads, materials and component classes. The final component should be designed based on the actual loading and the relevant safety factors. The criticality of the component along with the knowledge of the material and certainty of the load determine the relevant safety factor.

Due to the use of turbulent inflows in the simulations, the characteristic load may not be captured in the limited time histories. Therefore some events using turbulent stochastic inflows will need to have extreme events extrapolated from the limited time history data, along with the IEC partial safety factor.

For certification purposes, the IEC provides the list of partial safety factors for loading, materials and component class. The IEC does allow for the modification of the safety factors if, through measurements, one can prove the partial safety factors are overly conservative.

2.5.2 Limit state analysis

The extreme and fatigue loading data are necessary for the limit state analysis of a given component. The first simulations and the design load case usually allow for the component to be designed against a maximum load event. The fatigue analysis uses the expected wind regime Weibull distribution and component time histories to calculate the cumulative damage fraction. Depending on the component, this is often carried out using the Palmgren-Miner rule. The time history data is weighted for the Weibull distribution for the normal running simulations and the component loads Rainflow counted. The number of abnormal running simulations has to be assessed by the turbine manufacturer (i.e., number of shut downs and start ups per day). These load histories are also Rainflow counted. The combination of all load cases to the fatigue analysis allows for the estimation of fatigue life.

2.5.3 Resonance analysis

To identify possible resonance problems caused by the interacting wind turbine drive train components, resonance analyses are performed in frequency domain. Usually the results are plotted in Campbell diagrams which allow identifying possible resonances. The resonance analysis only considers internal component dynamics. The results of resonance analyses are not linked to the wind turbine external loadings. Up to now, resonance analyses for wind turbines are only required by the GL guideline.

2.6 *Pitfalls in the current design practices*

The reason for failures in gearboxes and bearings is a multifold problem and no single reason, or one solution, can cover all the possibilities, see also Section 2.1.2. Several possible causes for the problem, seen from a designer's point of view, are outlined below.

2.6.1 Finding the maximum stress response

Given the open nature of the IEC design load cases, it is likely that the scenario that causes gearbox damage is included in the standard design load cases. However, as noted earlier, it is necessary for the designer to determine what load case is the critical one. This involves correctly modelling the turbine and components in one or more simulation tools, and correctly estimating the stress response due to the multi-axial loading. Any combination of loadings on a component could cause the maximum stress response, so all load case scenarios need to be simulated. The results then need to be determined to find the maximum stress response.

2.6.2 Data transfer between parties

If one does not know the design of the component, then only the loads are available, not the stress response. This is the data that is shared between the turbine designer and the sub-component suppliers. Ideally, the entire final design of the turbine would be available for simulations before the manufacturing process starts. This is often not possible or realistic. The loads given to the component supplier are determined from the preliminary simulations.

Changes to the component design during the manufacturing process need to be included in the simulation iterations. This is problematic when components are supplied by outside partners and manufacturers. Gearboxes and bearings are often manufactured by external suppliers. The simulation and dimensioning of gearboxes and bearings is dependent upon the manufacturers. Their in-house proprietary simulation tools are assumed to be used in the design and selection of components. There is very little information coming back from the component supplier that can be used to re-simulate and

fine tune the simulation model. The problem can also be in the opposite direction; if not enough loading information is given to the component engineering team.

In components that are designed in-house, the know-how to determine the critical load cases is also in-house. When a design needs modification due to a potential load case scenario, the design of the component can be modified and the turbine system re-simulated. Especially, in the field of rotor blades progress has been made due to the following facts:

- The blade response can be simulated rather accurately using beam models, although for larger blades there is still research ongoing.
- Important blade properties for the wind turbine overall behaviour have been identified due to previous research. Therefore, if one of these properties is changed then the process is repeated
- The blades undergo a full-scale verification test, including identifying of properties affecting wind turbine behaviour.

Also for rotor blades there are still failure issues to be solved, but especially the mechanical components did not yet even undergo a procedure similar to the rotor blades.

2.6.3 Design load cases not determined

It is also possible that the load cases that are relevant for the gearbox and bearings may not be taken into account. This could be because the design load case combination (wind condition and fault) has not been assessed as relevant by the person simulating loads of the wind turbine. More information into the failure modes of failed turbines could be used in a 'reverse engineering' exercise to determine the possible fault condition that caused the failure. An example can be events in the generator (loss of electrical grid, short circuit) where a condition may cause a load to originate in the generator that moves back through the drive train. This type of condition is not well understood or modelled. New operational requirements, such as low voltage ride through (LVRT) may also cause unforeseen loading and are not easy to model.

2.6.4 Limitations in simulation abilities

The complexity of wind turbines does not allow easy dynamic simulations. The reactions of gears, bearings, etc are complex in nature and can not be 100% accurately modelled. Unexpected reactions of bearings might be beyond the ability of simulation codes to model in a realistic time window [48]. The specific failure modes of individual sub components (i.e. individual ball bearings) have effects throughout the entire system. The IEC design load cases make assumptions based on the wind and control actions or faults of the turbine, but individual component failures are often beyond the scope of current simulations.

3. State-of-the-art measurement approaches

3.1 Introduction

In the present chapter the current measurement procedures followed during the WT design or certification process focusing on mechanical loading, are briefly described.

In section 3.2 the standard procedures for WT testing are discussed. The measurement load cases that are described within the IEC/TS 61400-13 [33] are presented in section 3.3. Following, the current procedures regarding the extrapolation of the measured loads in order to estimate lifetime loads are described. A review of the prescribed testing procedures in the design process and certification are presented in section 3.5. Finally, the pitfalls in the current validation practices are identified.

3.2 Power performance and load measurements according to IEC 61400

The basic document of the current standards and technical specifications related to wind turbine testing is IEC 61400-12 [29] in which the requirements for power performance measurements are specified. This document is thereafter referenced in a series of following IEC documents, among which are the measurements of mechanical loads [33] and power quality [30].

In general, these guidelines are followed by manufacturers and accredited institutes that perform measurement campaigns regarding prototype testing, project development and certification.

3.2.1 Power performance and wind inflow measurements

The requirements for WT power performance and wind inflow measurements are described in IEC 61400-12 [29]. The focus of the requirements is the measurement accuracy of the basic parameters:

- The 10 minute average wind speed at hub height
- Power output
- Air density

Special attention is paid on the instrumentation details and on the avoidance of any obstacle shadowing. Further constraints are imposed when the measurements are performed on complex terrain, where a site calibration campaign is necessary. In the document a methodology is presented, based on topographic calculations, for classifying the test site as flat or non-flat. The classification decides the necessity for the performance of site calibration campaign, which results to a more accurate estimation of the hub height wind speed at the wind turbine position.

Turbulence is recorded, but does not affect directly the data processing. For instance, turbulence is used for determining the anemometer measurement uncertainty. In related standards turbulence is used as a limiting parameter for the determination of site calibration results.

Although it is expected that other wind inflow characteristics, such as wind shear and turbulence, also may affect the wind turbine power curve, these magnitudes are not implicated in the analysis process.

In special cases, mostly for research, the wind inflow is better described by the aid of multiple level measurements and use of 3D sonic anemometers (e.g. [10], [44]). Recommendations for those cases do not exist and the data processing procedures are not standard.

Power curve measurements are performed by the manufacturer during wind turbine development (development of controller, low noise emission versions etc) and during

certification process. Also, these measurements are often repeated by developers, during acceptance tests of wind farms, in order to verify the 'guaranteed' by the manufacturer power curve.

3.2.2 Mechanical load measurements

Mechanical load measurements are performed mainly for the following purposes:

a) Support of the design process

In this stage the mechanical load measurements are used either for direct estimation of loads on a component under design or for the validation of aeroelastic or other simulation models. WT design is based mainly on the use of aeroelastic models, as discussed in chapter 2.

b) Certification

During the certification process, the existence of experimental data facilitates the work performed by the certifying body, in assessing the manufacturer's design. This may also include the verification of models used by the certifying body. Also, the review of the experimental data ensures (within the limitations posed from the relatively short testing period) that phenomena outside the modeling capacity do not exist.

c) Direct determination of structural loads in specific conditions

In specific cases, where a WT component experiences unexpected structural problems, a direct determination of the loads via a measurement campaign, specific for the component, is preferred.

The technical specification IEC/TS 61400-13 [33] describes the procedures for performing mechanical load measurements. In a sense the document sets the basic requirements for a measurement campaign supporting certification purposes.

In the document the following are described:

a) Wind turbine load cases to be measured (MLCs)

These cases refer to the main external conditions and the operational conditions of the wind turbine during the test. They correspond to the design load cases (DLCs) related to fatigue analysis, as defined in IEC 61400-1 [27].

b) Quantities to be measured

These refer to the mechanical load magnitudes, WT operational as well as the wind inflow parameters (Table 3-1). In the standard it is recognized that some of the wind turbine operational parameters might be provided by the control system of the wind turbine, provided that they comply with the accuracy specifications outlined in the standard. The document is not restrictive but sets the fundamental load magnitudes to be the blade root, rotor and tower loads. Furthermore, depending to the criticality of the safe operation of the WT, to be judged by the certification body or the manufacturer, the load magnitudes to be measured should be extended, accordingly. It must be noted that there are magnitudes that are recommended to be measured (i.e. wind shear or temperature gradient) in order to characterize the specific campaign, without proposing any specific processing procedure, based on these parameters.

Judging from the above, if one wants to classify the load measurements performed for the validation of the sub-components addressed within the PROTEST project, these could be set as follows:

- (1) For the yaw system: Load measurements prescribed for the tower top correspond to loads components that are transferred from the nacelle to the tower. However, following the standard, a classification of the captured load case does not have to be made according to the status of the yaw system operation (yawing or keeping nacelle

position). As already noted, according to the IEC/TS 61400-13 standard, actuator loads regarding the yaw system are prescribed only if it is judged that these are critical for the safe operation of the WT.

- (2) For the pitch system: Load measurements prescribed for the blade root correspond to load components that are transferred from the blade to the hub. Similar to the yaw system, a classification of the captured load cases does not have to be made depending on whether the blade is momentarily pitched or not (operation of pitch system). Additionally, similar to the yaw system, pitch actuator loads are prescribed, only if it is judged that these are critical for the safe operation of the WT.
- (3) For the gearbox: Load measurements prescribed for the rotor are the only load components prescribed by the standard that could be connected with loads on the gearbox. This is also affected by the actual WT configuration and the selection for the position of measurement of the loads. IEC/TS 61400-13 does not specify in detail measurement locations for these loads.

c) Measurement techniques

The described measurement techniques include sensor selection and application practices, calibration and uncertainty analysis procedures. Especially for the load measurements on the wind turbine, although IEC/TS 61400-13 is not restrictive, strain gauge bridges applied on the structure are recommended. Their output is recommended to be related directly to an applied load level, wherever feasible.

According to IEC/TS 61400-13 the data acquisition is to be performed for the collection of both time series and statistical data. The length of the time series is connected to the measured load cases (MLCs) prescribed in the standard, while the minimum time-series number is classified depending on whether the load measurements are performed for model validation or empirical load determination. The sampling frequency is prescribed to be at least eight times higher than any significant frequency in the relevant signal, while analogue filters with a cut-off frequency at least three times higher than any significant frequency in the relevant signal shall be used. On Table 3-1 the last column indicates the relevant sampling frequency for the load quantities, as this are usually applied during load measurements campaigns. Current validation campaigns may involve load and load related magnitude measurements on components that are not defined within IEC/TS 61400-13. In the case of testing on the high speed side of the drive train, including torque and rpm measurements, significantly higher sampling rates should be used. The sampling rate, for such measurements, should be appropriate for capturing not only the normal operation but also any transient events, such as grid fault-ride-through events.

d) Processing guidelines

The processing guidelines refer to procedures for data validation and selection, data analysis and presentation and reporting formats.

Fundamental load quantities	Remarks	Sampling Frequency (not prescribed by IEC)
Blade root loads	bending moments in two perpendicular directions (flap, lead lag)	≥ 64 samples/s
Main shaft torque		≥ 64 samples/s
Rotor yaw and tilt loads measured on main shaft or	bending moments in two perpendicular directions	≥ 64 samples/s
Rotor yaw and tilt loads measured at tower top	bending moments in two perpendicular directions and tower torsion	≥ 64 samples/s
Tower top loads	bending moments in two perpendicular directions	≥ 64 samples/s
Tower base loads	bending moments in two perpendicular directions	≥ 64 samples/s
Wind turbine operation quantities		
Electrical power	-	≥ 1 sample/s
Rotor speed	-	≥ 64 samples/s
Rotor azimuth position	-	≥ 64 samples/s
Pitch angle (if applicable)	-	≥ 64 samples/s
Nacelle yaw position	-	≥ 1 sample/s
Status signals	WT, grid connection and brake.	≥ 1 sample/s
Meteorological quantities		
Wind speed and direction	measured at hub height	≥ 1 sample/s
Air temperature and density	Not used for normalization	≥ 1 sample/s
Wind shear	recommended to be measured	≥ 1 sample/s
Temperature gradient	recommended to be measured	≥ 1 sample/s
Nacelle anemometer	Optional, if a nacelle anemometer calibration is available	≥ 1 sample/s

Table 3-1: Quantities to be measured according to IEC/TS 61400-13 [33].

3.2.3 Power quality measurements

In document IEC 61400-21 [30], the procedures for testing and assessment of power quality characteristics of grid-connected WT are given. The continuous increase of wind power penetration in the power systems, has led to the establishment of more strict regulations concerning the wind turbine connection to the grids. Such requirements are the Fault Ride Through Capability (FRT) of wind turbines, the reconnection and return to the pre-fault operating conditions in the shortest possible time and the production of controllable amounts of active and reactive power during the faults.

Power quality is not directly related to mechanical load measurement campaigns. On the other hand, a short circuit within the grid, with the WT running, results in torque levels significantly

higher than the rated values and, as a consequence, the mechanical drive and shaft system is subjected to loading, that has to be taken into account. Additional constraints might be imposed on other systems of the wind turbine, in configurations where other components of the turbine are used to control the overall operational behaviour during these cases (e.g. the pitch system in cases Blades are pitched with a specific pitching speed as a reaction due to grid loss).

3.3 Measurement load cases according to IEC.

The measurement load cases described in IEC/TS 61400-13 [33] are summarized in the following table:

MLC No	Load case	Corresponding DLC IEC61400-1	Wind conditions
Steady state operation			
1.1	Power production	1.2	Cut-in to cut-out
1.2	Power production plus occurrence of fault	2.4	Cut-in to cut-out
1.3	Parked (rotor stopped or idling)	6.4	All wind speed range
Transient events			
2.1	Start-up	3.1	cut-in and above rated
2.2	Normal shut down	4.1	cut-in, rated and above rated
2.3	Emergency shut down	5.1	cut in and above rated
2.4	Grid failure		rated and above rated
2.5	Over-speed activation of the protection system		above rated

Table 3-2: Measurement load cases according to IEC/TS 61400-13 [33].

It is stated that additional MLCs may be necessary depending on the wind turbine concept, control and safety strategy.

The measured load cases for normal power production are classified in wind speed and turbulence intensity bins. The minimum number of recordings is prescribed in terms of number of recordings per wind speed bin and number of filled turbulence bins. Accordingly, the MLC regarding transients and faults are classified with wind speed, and the minimum number of recordings is stated. For each load case the standard sets a recommended and a minimum time series length, which are 10 minutes and 2 minutes time series respectively. A time series length for load cases corresponding to normal transient events is not prescribed within IEC/TS 61400-13.

The aim of the procedure is to collect a representative amount of data, distributed around the complete WT operational wind speed range, in a feasible short time period.

3.4 Extrapolation of measured loads to lifetime loads

The result of a load measurement campaign is the footprint of the WT loading within specific wind inflow characteristics. In order to exploit the data towards the estimation of lifetime loads the following are needed:

Extrapolation of measured fatigue spectra to other turbulence levels

Within IEC/TS 61400-13 [33] two procedures for spectra extrapolation are presented.

- (1) The first procedure is based on linear extrapolation, having turbulence intensity as the independent parameter and the load range as dependent for each specific cumulative cycle count. The procedure is accepted if not applied for turbulence levels well above the last level captured.
- (2) The second procedure is based on spectrum distribution modeling. Contrary to the previous method, in which only the missing data are calculated through extrapolation, in the spectrum distribution modeling, a model is developed that simulates the fatigue spectrum at each wind speed and turbulence value. The measured spectra are fitted to a quadratic Weibull distribution, whose parameters are modeled against wind speed and turbulence intensity. For given wind speed and turbulence level the distribution parameters are calculated and then the spectrum is generated through an inverse procedure.

Synthesis of lifetime fatigue spectra

Having defined the wind regime (i.e. from WT class) and the WT duty cycle, the 10 minute fatigue spectra can be summed up to create the lifetime spectrum.

The estimation of the lifetime fatigue spectrum with such a method presents the drawback that the low frequency part of the spectrum is erroneously void.

In this context, the procedures described in IEC 61400-1 [27], as informative annexes (F & G), regarding the statistical extrapolation of loads for extremes and fatigue spectra may be used. These procedures are equally applicable to simulation data and experimental data, given the existence of a minimum data volume. The procedures are based on probabilistic methods and distribution moment modeling.

3.5 State of the art testing procedures

Apart from procedures and measurements described in the above mentioned standards [29], [30] and [33] currently other measurements are also performed on a case per case approach to provide the necessary input for designers and manufacturers. These include both load measurements on specific components that are of interest and measurements to verify the behavior of some wind turbine components during validation, but also as part of the condition monitoring of the whole wind turbine. In parallel, improvement on equipment (e.g. 3D sonic anemometers) allows for better estimation of the in-flow parameters and in turn better estimation of the loading imposed on the wind turbine components (e.g. [10], [58]). These measurements, however, are not standardized, except for measurements related to condition monitoring, and are usually part of research and development processes.

Part of the measurements related to condition monitoring, especially for the drive train might be used as an alternative for verification of model input data. Instrumentation and measurement procedures employed for condition monitoring are outlined in [18], which closely follows [1]. For the purposes of condition monitoring and thus, the long term trend analysis to decipher deterioration of components, focus is given on measuring the dynamic response of the wind turbine on pre-defined locations. Omitting the parameter of long term monitoring and trend analysis, measurements captured through this approach could be used for verification of dynamic models of the structure. However, application on a real structure would imply the ability to understand and estimate the structural response including uncertainties inherent in the various structural components. For example small increased loading on a wind turbine under investigation in comparison with the theoretical model, would have to be traced back for identifying whether this result is due to small aerodynamic asymmetry of the rotor, which is

accounted for in manufacturing tolerances, or due to neglecting parameters in the theoretical model.

Additionally, within research projects aiming to improve aspects in the wind energy generation field, there is a number of reported specialized measurements. These involve mainly details of the drive train, focusing on the gearbox. Such measurements have been reported, for example, in [57] and [51]. In both cases measurements involved monitoring of the gearbox movement and torque measurements inside the gearbox. In [58] measurements involved recording of the axial force on the back plate of the gearbox, while in [51] additional measurements are foreseen to monitor instead of the axial force the corresponding displacement, in parallel to capturing movements of the generator and the coupling torque. Extensive measurements on and especially inside the gearbox, similar to the above mentioned ones, have become current practice during the certification of new products. More specifically, during prototype trials (as required by certification bodies [17]) the gearbox is tested not only on test rigs but also at a wind turbine and the behavior of the system and its subcomponents is monitored comprehensively, including loading and movements (displacements) on internal shafts and gears in parallel to the overall response of the wind turbine.

Moreover, requirements related to the electrical response of the wind turbine, which should be verified during prototype testing, have led to integrated measurements procedures, by monitoring simultaneously mechanical loading and electrical characteristics of the wind turbine with emphasis on the drive train and the high speed shaft [43].

3.6 Pitfalls in the current validation practices

The data from a load measurement campaign can be used for validation of the design (in case of a prototype) as well as for model tuning and verification. In these practices there are issues that can be identified as pitfalls.

Uncertainty of the load measurements

The majority of load measurements on the wind turbine are performed by measurement of the strain exhibited on the component, which is then transformed to the applied load. In general the uncertainty of the load measurements is of the order of 5%. The uncertainty of the correlation of the load with the local strain (expressed either as cross talk, sensor misalignment, inappropriate sensor location etc) is the main contributor. This uncertainty does not only depend on the equipment but also on the procedure of conversion of the strain to load. Examples of the uncertainties involved in these conversions for the load measurement on the wind turbine components can be found in [D. J. Lekou, F. Mouzakis, WT Load Measurement uncertainty: Load-Based versus Analytical Strain-Gauge Calibration Method, Journal of Solar Energy Engineering, Vol. 131/011005, 2009].

Limited amount of experimental data

Several reasons (cost, time shortage, wind regime etc), often keep the amount of experimental data limited to the minimum sets prescribed by the standards. A larger data base, especially towards higher wind speeds and turbulence intensities facilitates the design validation.

Limited description of the wind inflow

Until recently, the wind inflow description for the load measurements was coming from a few cup anemometers and vanes. The use of 3D sonic anemometers enables the identification of parameters such as wind inclination and turbulence components. The existence of standardized procedures for analyzing data against load driving parameters such as shear, turbulence components or atmospheric condition would enhance the value of the data.

4. Comparison of design and measurement approaches

Results of prototype measurement campaigns are being used by R&D departments among others to verify the design approach. In addition to that, measurement results are also being used by certification bodies to verify the design loads. In this chapter, first results from a European Benchmark project VEWTDC are presented and the practical experiences of wind turbine and component designers (obtained from interviews) and their own experiences are summarised.

4.1 Results of Benchmark exercises

In the EU project VEWTDC (*Verification of European Wind Turbine Design Codes*) [52], various design codes have been compared with measurement results. During the verification process the following sources of discrepancies between measurements and calculations were observed.

1. Discrepancies due to errors in post-processing and coordinate systems: Differences between calculations and measurements simply can be attributed to misunderstandings of errors on file formats, coordinate systems, etc. Most of these errors however can be eliminated if all details are considered with care.
2. Uncertainties in machine description: In the description of the turbine some parameters are unknown or have to be estimated. The importance of some of these uncertainties can be quantified by means of sensitivity studies. Significant effects of, among others, the structural damping and the unknown aerodynamic and mass unbalances between the blades have been found. A change from 1 to 2% structural damping decreased some loads by approximately 15%.
3. Uncertainties in the prescribed external conditions: Uncertainties in the external conditions are of great influence. This holds in particular for the wind input. The wind input is fed to the aeroelastic codes in the form of spatially distributed wind fields as a function of time. These wind fields are generated by stochastic wind simulators which use the statistics of the wind as input (mean wind speed at hub height, turbulence intensity, wind shear, turbulent length scales, and coherence parameters). These statistics are derived from measurements on meteorological masts, which are placed some distance away from the turbine. The wind conditions are usually measured at hub height only or sometimes at different heights over the rotor plane. In this way it cannot be guaranteed that the real wind is captured. Even if the statistics of the wind measured at the mast would be fully representative for the location of the wind turbine, one should bear in mind the statistical variability of the wind: For the same mean wind speed, turbulence intensity, turbulence length scale, turbulence spectrum and coherence function, wind simulators generate different wind fields when applying different random seeds. Sensitivity studies showed a very large effect of these different random seeds (in the order of +/- 10%).
4. Uncertainties in the load measurements: In some cases, differences between measurements and calculations cannot be explained by errors in the model but doubt existed on the quality of some measurement signals.
5. Uncertainties due to different implementation and interpretation of the input description: Even when a complete input description of the load cases and the turbines can be made, the descriptions always leave some freedom for the analyst, i.e. the number of time steps, elements, etc. (in both the aero elastic code as well as the wind simulator) are code dependent and cannot be prescribed. As a result, one should realise that the observed differences between calculations and measurements partly depend on the analyst and his/her experience: Different results can be delivered even if the same code and the same input description is used.
6. Differences caused by fundamental model effects: The codes which are used by the participants in the VEWTDC project are based on different models (i.e different wind model, aeroelastic modelling, numerical solutions etc). This of course leads to different outcomes.

4.2 Practical experiences

4.2.1 Motivation

The experiences of designers and those of the authors revealed that the comparison of measurement results with the design results can be done for various reasons; the most important ones are:

- identifying and quantifying input parameters of the design model (e.g. damping factors, spring constants, natural frequencies, settings of the controller) and tuning the design model;
- identifying differences between measured quantities and design values and checking the correctness of design model and/or measurement set-up;
- estimating uncertainties in the design model, among others to underpin the applied safety factors;
- completing the set of design loads in case the models are not suitable to calculate certain load cases (e.g. faulted situations, oblique inflow).

As compared to the discrepancies mentioned in Section 4.1, the practical experiences deal with similar issues, but from a different point of view. For instance:

- The discrepancies 1, 2, 5, and 6 indicate that differences exist between measurements and calculations and are presented as findings from the benchmark study. At present, instead of concluding that uncertainties in the machine description (damping factors, etc.) and in the model exist, the measurements are now being used to derive input parameters and to fine-tune the model. The measurements are compared with calculations to identify and quantify the differences and to make sure that the model can be used for those conditions and load cases that are unlikely to occur during a measurement campaign (extrapolation). One can think of extreme gusts, high turbulence, oblique inflow, etc.
- The uncertainties in the measurements (discrepancy 4) are reported as "...doubt exists ...". At present detailed investigations are being done by measurement institutes to minimise the uncertainties to the extent possible. Still uncertainties do exist (and will always exist), but they are usually being identified and explained before the measurement results are going to be used for model verification. One can think of the influence of temperatures on strain measurements, misalignment of strain gauges, stress concentrations near the strain gauges, calibration uncertainties, etc.
- In discrepancy 3, it is mentioned that different starting seeds lead to different loads due to the statistical variability of the wind. At present, this statistical variability is accepted and running more than one time simulation per bin is common practice since the calculation time has been strongly reduced. Comparing measurements and calculations should not only be done at the basis of single time series, but also on the basis of statistical parameters representing a larger number of time series.

4.2.2 Approach

The comparison between measured quantities and design values can be done in various ways, and at various levels. For instance, designers can compare the 20 years load spectra, or they can analyse time series. From the interviews and the authors' own experiences a kind of common approach could be determined. In general it can be said that first of all the statistical values (azimuthally binned, scatter plots, etc) and natural frequencies are being compared. If differences are observed, more detailed investigations are being done on the level of time series to explain the causes of the differences.

Wind conditions

First of all it should be checked if the meteorological conditions used for the wind conditions are the same as during the measurements. An example of a scatter plot representing the turbulence intensity as a function of the wind speed is given in Figure 4.1. In addition the shear conditions can also be compared (if the wind speed is measured at more than one height!).

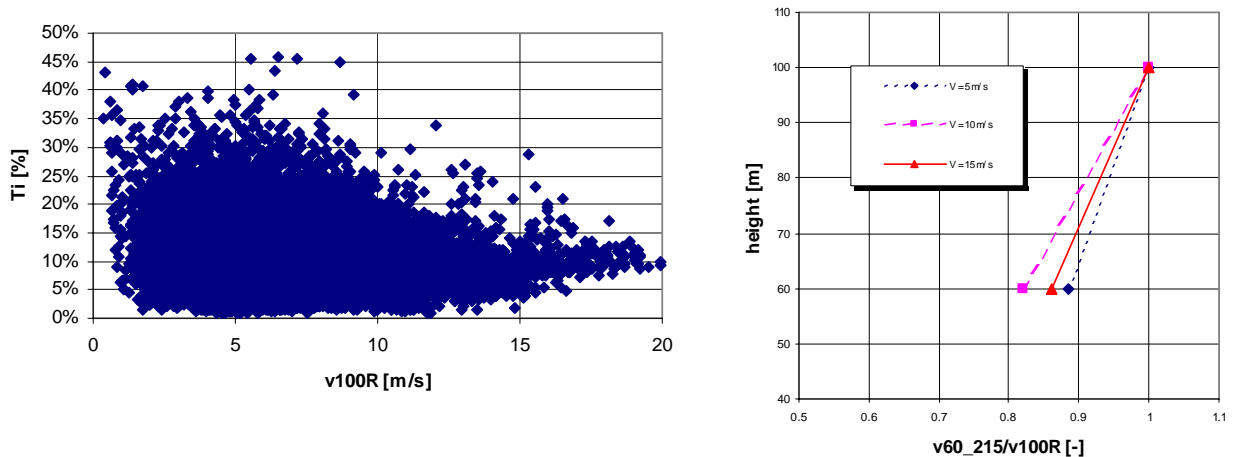

Figure 4.1: Example of plots to verify the wind conditions (turbulence and wind shear)

Azimuthally binned

It is very informative to plot the loads as a function of the rotor azimuth angle as is done for example in Figure 4.2 (rotor blade, edgewise and flap wise bending moments). Similar plots can also be made for other loads (main shaft, tower, etc.)

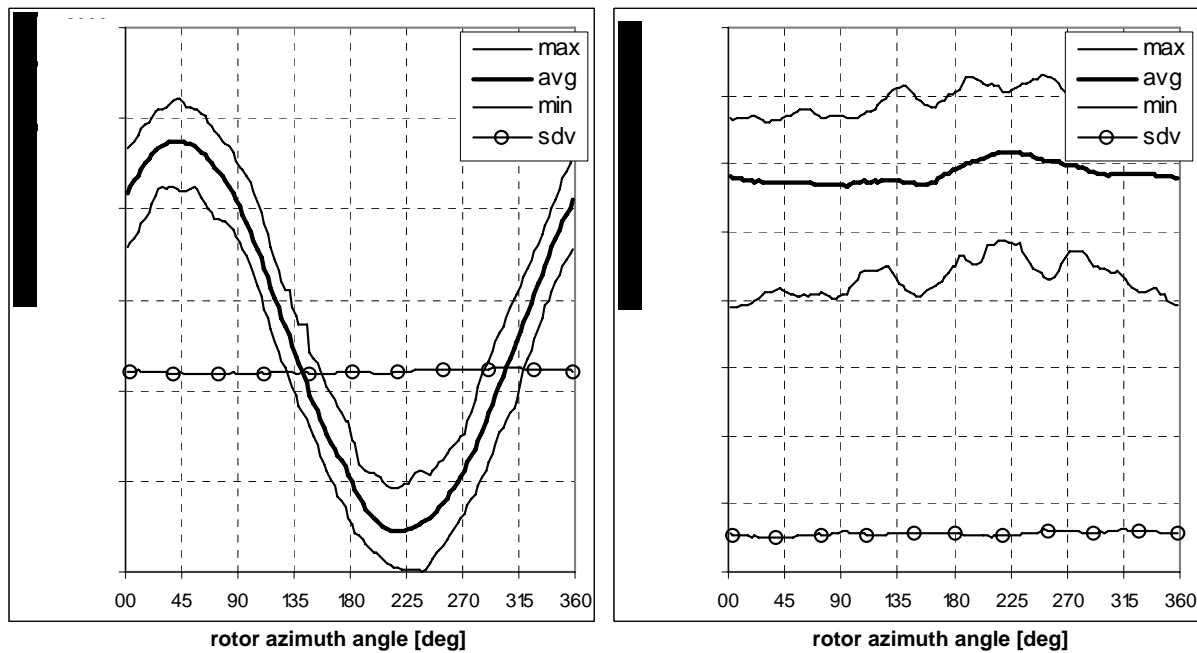

Figure 4.2: Edgewise (left) and flap wise (right) bending moment of rotor blade.

The measured minimum, mean, maximum values and the standard deviation should correspond to the calculated values. If not, the differences are being investigated in more detail. The differences may be caused either by the different behaviour of the turbine in reality or by simulation or measurement errors. High maximum values or standard deviations for instance may be caused by unexpected vibrations of the turbine. High (or low) mean values may be caused by incorrect calibration of the strain gauges, or drifting of the offset values. Unfortunately, a kind of “recipe” on how to investigate the differences in detail cannot be given, it is very much dependent on the findings.

Scatter plots as a function of wind speed

Many signals (electrical power, rotor speed, blade root bending moments, tower bending moments, rotor torque, pitch angle, tilt and yaw moments, etc) are strongly correlated with wind speed. By comparing the statistical measured values with the calculated values, for instance by means of graphs like shown in Figure 4.3, differences can be easily determined. Depending on the differences, one can decide to look for further details and causes. The statistical data are usually the 10 minutes averaged values; however equivalent loads (taking into account material properties) can also be plotted and compared in the same way.

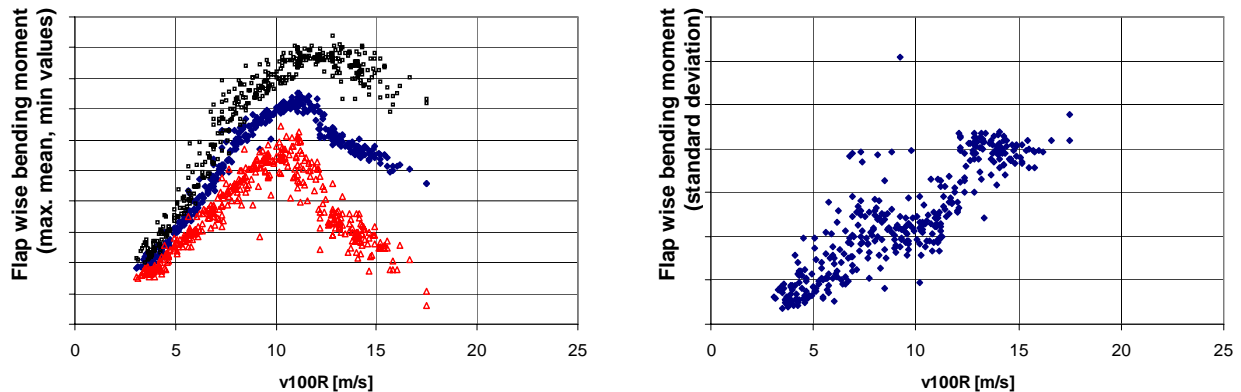

Figure 4.3: Flap wise bending moment of rotor blade (y-axis) as a function of the wind speed at hub height (x-axis) (left: max, mean, min values; right: standard deviation)

Relationships between turbine signals

Some signals (both measured and calculated) are expected to correlate with other turbine signals. E.g. the flap wise bending moments of all three blades are expected to be in the same order of magnitude at certain wind conditions. One can compare the loads of blade 1 and 2, 2 and 3, or 3 and 1 in scatter plots. An other example is the correlation between (1) the sum of the three in plane bending moments and (2) the main shaft torque as given for example in Figure 4.4. Such scatter plots can be informative to determine differences between measurements and calculations.

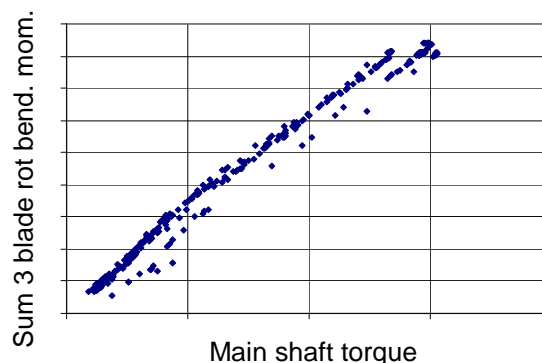

Figure 4.4: Sum in plane blade bending moments as a function of the main shaft torque

Load spectra

From the calculated and measured load cases and taking into account a certain wind climate (Weibull distribution and turbulence intensity) one can construct the 20 years fatigue spectra. Differences as given for example in Figure 4.5 may show up between the calculated and measured load spectra. The load spectra actually represent a probability density function of the load as a function of produced power and /or operating speed and /or generated torque. They should be handled and interpreted in a more statistical manner.

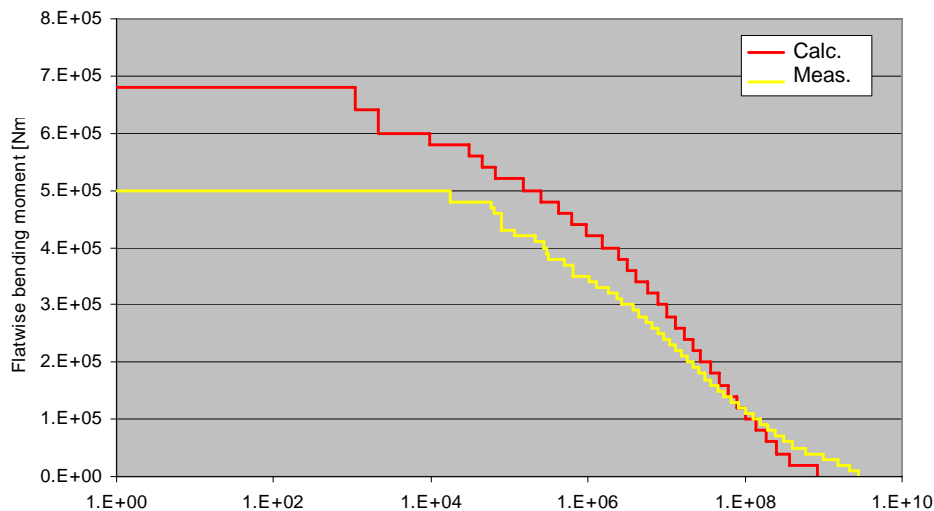

Figure 4.5: Blade flatwise bending moment, measured and calculated

Frequency spectra

Frequency spectra reveal among others if the actual natural frequencies of components correspond with the calculated values. If the calculated natural frequencies differ from the actual values, oscillations may show up in reality which were not expected. If the natural frequencies are the same (measured and calculated) but the amplitudes differ, probably the damping used in the model is not correct.

Furthermore, frequency plots may show measured peaks at certain frequencies which are not caused by natural frequencies. Such peaks may also be caused by wrong settings of the controller.

Time series

In all cases it is worthwhile to analyse the individual time series. The responses on e.g. gusts, pitch and yaw actions, start-up or shut down actions, etc. can be investigated in detail and may give reason for instance to fine-tune the models, improve the measurement set-up, or correct settings of the turbine.

4.3 Final remarks

The authors have included in this chapter the approaches that are presently being used to compare measured data with design data. The following remarkable issues were noted.

- The IEC-61400-13 standard [33] clearly describes how mechanical load measurement campaigns should be carried out. However, this standard does not include a procedure how to compare the measured data with the design data.
- From the VEWTC project and from interviews with designers it is concluded that the measured data are being used for checking the correctness of design models, for quantifying input parameters of design models, for estimating uncertainties in the design models, and for completing the set of design loads in case the models are not suitable. A clear procedure for doing this has not been found.
- The information found about comparing design and measured data is limited to the global turbine loads. The authors have not found any publication or report on comparing measured data of mechanical components with component design data.

5. Status and trends of standards and certification procedures

The certification and the design of turbines are based on several guidelines and standards specifically developed for the wind turbine industry [17], [35]. Regarding the overall turbine safety the most frequently used are GL's wind guideline and the IEC standard [27], [28]. In these standards the principal requirements for the analysis of the wind turbine regarding safety are given, mainly as requirements for the safety system, environmental conditions, load case definitions and safety factors. From these the loads and safety requirements for the different components under investigation are extracted.

The GL wind guideline was first published in 1993, while the second edition was issued in 2003. Additionally the second edition of the Guideline for offshore wind turbines was published in 2005. In the GL wind guideline the whole wind turbine system, including its subsystems and components is considered. At the time being the GL wind guideline is reviewed, it is intended to publish the 3rd edition of the GL wind guideline in 2010. This revision will include results from the present project.

The first version of the IEC standard (IEC 1400-1) was published in 1994, followed by a second edition in 1999 (IEC 61400-1) and a third in 2005. In the subsequent developments the experience from the industry, the increase of turbine size and the development of analysis tools were considered. At the time being an amendment to the 3rd edition of the standard is under preparation. In this amendment the attempt is made to solve problems encountered by the first applications. Since the IEC standard only describes requirements, several other wind turbine related standards and technical specifications were developed in parallel or are under development.

Standard	Date/Status	Edition	Title (short)
IEC 61400-1	2005-08	3	Design Requirements
IEC 61400-1 Amendment 1	FDIS	3	Design Requirements
IEC 61400-2	2006-03	2	Design requirements for small wind turbines
IEC 61400-3	FDIS	1	Design requirements for offshore wind turbines
IEC 61400-4		1	Design and specification for gearboxes
IEC 61400-11	2006-11	2.1	Noise measurement
IEC 61400-12-1	2005-12	1	Power performance measurement of electricity producing wind turbines
IEC 61400-12-1		2	Power performance measurement of electricity producing wind turbines
IEC 61400-12-2	CD	1	Power performance of electricity producing wind turbines based on nacelle anemometry
IEC 61400-12-3		1	Wind farm power performance testing
IEC/TS 61400-13	2001-06	1	Measurement of mechanical loads
IEC 61400-13		2	Measurement of mechanical loads
IEC/TS 61400-14	2005-03	1	Declaration of apparent sound power level and tonality values
IEC 61400-21	2008-08	2	Measurement and assessment of power quality characteristics of grid connected wind turbines
IEC 61400-22	CD	1	Conformity testing and certification of wind turbines
IEC/TS 61400-23	2001-04	1	Full-scale structural testing of rotor blades

IEC 61400-23		2	Full-scale structural testing of rotor blades
IEC/TR 61400-24	2002-07	1	Lightning protection
IEC 61400-24	CD	1	Lightning protection
IEC 61400-25-x		1	Communications for monitoring and control of wind farms
IEC 61400-26		1	Availability for wind turbines and wind turbine plants
IEC WT01	2001-04	1	System for Conformity Testing and Certification of Wind Turbines
ISO 81400-4	2006-09	1	Design and specification for gearboxes

Table 5-1: Status of IEC standards (publishing date, FDIS=Final draft, CDV=Committee draft for voting, CD= Committee draft, no date= in preparation)

At the time being, both the GL Guideline as well as the IEC 61400 group of standards are successfully applied in the wind energy branch.

5.1 Assessment of site and operational conditions and associated load cases

For the calculation of loads on wind turbines the relevant conditions at the site have to be considered. Since wind turbines are standardized serial products they are usually designed for generic conditions which should cover most future sites. Thus, for the design “type classes” are applied for the wind conditions and a type certification is performed. As a second step in the planning phase, it has to be shown, that the conditions at the erection site are less severe than the generic assumption considered and that the turbines are suitable for the site. This can be proven either by showing that the load driving wind conditions are more benign, or by a full load analysis and adjacent load comparison at defined cross sections. The main parameters to be considered during site assessment for a wind farm are the site morphology, the load influencing environmental conditions (wind, ice, seismic activity, wake influence from neighbouring turbines, soil and electrical grid conditions).

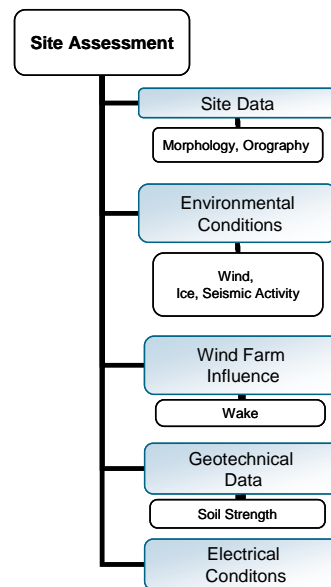

Figure 5.1: Components of site assessment

Within the type certification process the assessment of the prototype test is included. The latter is composed of the evaluation of measurement campaigns with respect to the power curve, the noise emission, the power quality, the dynamic behaviour and the mechanical loads. The wind and operational conditions at the site are measured according to the requirements of the IEC61400-13 [33] in case of prototype tests for type certification. In the standard the relevant measurement load cases (MLCs) for operational, parked or idling and transient conditions (starts, stops, safety system activation) are defined. They shall correspond with the standard or guideline used for the design. Further the capture matrix, the components to be measured and the measurement techniques are defined. The meteorological quantities to be measured are:

- Wind speed
- Wind shear
- Wind direction
- Air temperature
- Temperature gradient
- Air density

The operational quantities are:

- Electrical power
- Rotor speed
- Pitch angle
- Yaw position
- Rotor azimuth
- Grid connection
- Brake status
- Wind turbine status (relevant parameters)

In case of prototype tests and in order to minimise other disturbing effects, siting of the test turbine in complex terrain is to be avoided. In general the requirements of IEC 61400-12 standard [29] on site assessment apply.

From the measured wind conditions at the site and the analysis of the flow conditions using flow models a precise characterisation of the site can be achieved. Essential is the detrended standard deviation of the wind speed (turbulence intensity) as a function of wind direction as well as upflow conditions.

5.2 Numerical and experimental determination of component loads

5.2.1 Introduction

In the scope of the certification of a wind turbine a design life of 20 years has to be verified. An assessment of sufficient strength in terms of the ability to withstand fatigue and extreme loading is therefore necessary.

In contrast to many other industries and applications wind turbines are subject to independently acting loads represented by forces and moments. The use of standardized load spectra is therefore not common. Today load time series obtained by simulation are used for the fatigue assessment of machinery components and structures. One important aspect with respect to load assumptions is to maintain the phase relationship between the individual load components. Consequently, the determination of component loads for wind turbine applications may become rather complex.

5.2.2 Determination of component loads

Wind turbines are subjected to environmental and electrical conditions which may affect their loading, durability and operation. These external conditions are subdivided into normal and extreme, depending on their probability of occurrence.

Loads are nowadays based on aeroelastic simulation codes using stochastic wind fields and modal analysis techniques. Results of the simulations are time series of forces and moments including their phase relationship for the most important normal and extreme loading conditions.

The loads are calculated at several cross section points of the wind turbine. Loads that have their origin in the centre of the blade roots, the rotor centre or in the centre of the yaw bearing are of interest for the verification of machinery components and structures. Taking this as basis it is common practice to derive component loads by means of equivalent static systems.

For the verification of the components ability to withstand extreme loading, extreme values of individual load components together with simultaneously acting loads are extracted from time series. Extreme load combinations are recorded in extreme load tables which are to be used for the strength verifications.

For the fatigue strength verification cycle counting methods (e.g. rainflow counting) are used to derive rainflow matrices, load spectra or damage equivalent loads of individual load components. In cases where components are subject to unidirectional loading these data may be used as decisive loading parameters. For components that are subject to multi-directional loading, time series together with results from e.g. finite element analysis have to be used for the calculation of stress time series (see section 5.3). This is essential in order to maintain the phase relationship.

The processing of loads for the verification of gears and bearings of a gearbox differs in part from that of other components, e.g. rotor hub or mainframe. For the determination of applicable load spectra, load duration distributions (LDDs) have to be derived. The range between minimum and maximum of the time series related to the load component to be investigated (e.g. torque of the main shaft) is divided into an arbitrary number of bins. Each data point is sorted into the load level of the respective bin. The number of counts for each bin is a measure for the duration of the respective load level.

5.2.3 Verification of component loads, resonance analysis

Simulation codes that are commonly used for the calculation of loads focus on global loads, e.g. for the design of tower and rotor blades. The model of the drive train is subject to a strong simplification. It is usually represented by a spring-damper system that consisting of two masses and one rotational stiffness only. Still, the design of drive train components is based on global loads that are transformed to local component loads. Neglecting dynamic properties and internal loads originating from within the drive train are just some disadvantages of this approach.

Multi body and finite element approaches have found their way into the wind energy branch recently. They enable a more realistic display of the real machine. Within Certification the evaluation of the dynamic behaviour of the drive train has become an integral part of the Design Assessment. The aim is to determine the resonance behaviour of the drive train and to verify the model parameters that represent the drive train in the global simulation model. At the same time it is possible to verify the applicability of the transformation of global loads to local component loads in terms of the evaluation of resonance conditions within the operating range of the wind turbine.

For the assessment of the dynamic behaviour of the drive train the real design is simplified into a simulation model. The result is a mechanical model which might include non-linearities such as force elements representing gear meshes and bearings. The simulation can be carried out in frequency and/or time domain.

The analysis in frequency domain requires a linearized model. To achieve this, a certain state has to be chosen for calculating natural frequencies, mode shapes and energy distributions. This information is required for performing a resonance analysis. The evaluation of drive train resonances is done using Campbell-diagrams. Excitation frequencies that have to be taken into account are rotor speed, speed of gearbox shafts and mesh frequencies. Depending on the design of the drive train additional sources of excitation may be existent. The intersection points of natural frequencies and excitation frequencies are evaluated in more detail by the examination of energy distribution within the drive train.

For the simulation in time domain a start-up scenario of the drive train covering the entire operating range of the wind turbine is simulated. The electrical part of the turbine is approximated by applying the generators torque-speed curve at the high speed end of the drive train. Time series of mechanical properties such as torque and acceleration are evaluated with regard to load amplifications due to resonance conditions. Fast Fourier transformation and filtering are useful for this purpose.

The detailed drive train model is also expedient for the verification of model parameters used within global load assumptions. In most cases parameters to be verified are the resulting drive train stiffness and the generators moment of inertia. [38]

5.3 Component design strength and limit state analyses

5.3.1 Structural components

During the verification of design strength, component stresses have to be determined. For the assessment of structural components no standardized rules are applicable. The finite element approach is commonly used for the strength verification. GL's wind guideline describes requirements regarding finite element analyses. Once IEC 61400-4 is officially published it will include specifications using the finite element method with regard to structural components of gearboxes.

The load bearing structural components in wind turbines are mostly made of large, complex shaped spheroidal graphite iron castings and steel fabrications. Due to the remote operation, conservative safety requirements and long life expectancy, a long crack initiation phase is necessary. Based on these general conditions, suitable and reliable fatigue analysis procedures have to be applied on the components to be investigated.

A stress based analysis can be divided into two parts: the determination of stresses under fatigue loading and the determination of representative fatigue properties of the material under consideration. The life of a component is a function of these two aspects. Figure 5.2 shows a typical fatigue analysis procedure.

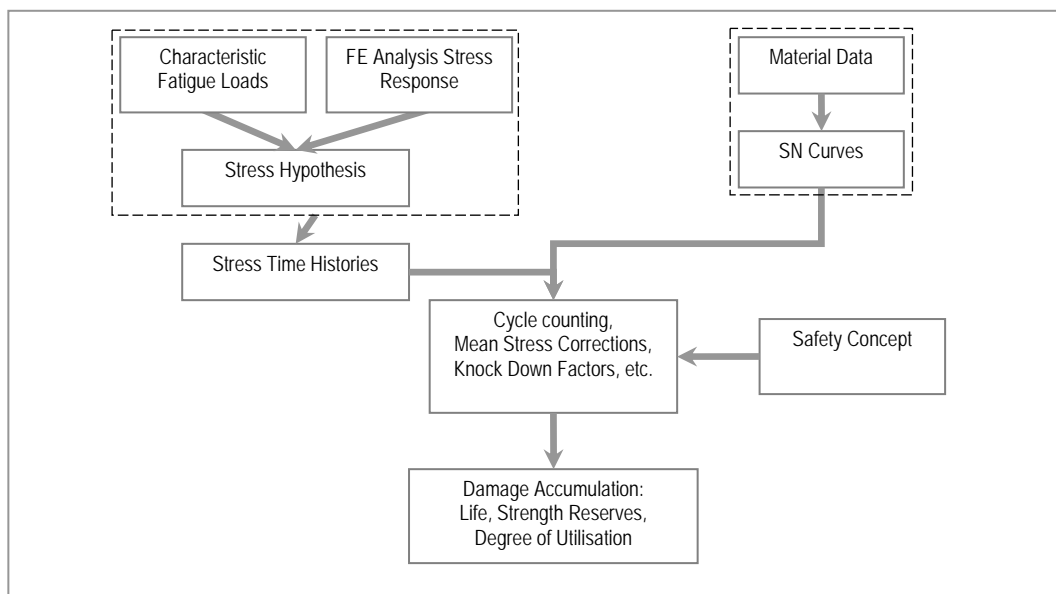

Figure 5.2: Fatigue Analysis procedure

The stresses in the component are calculated using appropriate stress hypothesis and then cycle counted to enable a comparison with applicable material data such as S/N curves. Different safety and knock down factors are considered in these calculations before damage accumulation is carried out to determine the component life and the degree of utilisation.

5.3.2 Gearboxes

To safeguard the operational reliability of gearboxes for wind turbines, a number of national and international standards and guidelines have been formulated in recent years. These standards and guidelines are, however, not intended as replacements for recognized standards, such as ISO 6336 [37] or ISO 281 [36]. On the contrary, they provide fixed rules (e.g. for determining the load distribution of spur and helical gears) and requirements (e.g. minimum safety factors) when applying these standards, with a view to adapting them to the operating conditions of wind turbine gearboxes.

Requirements set out in ISO/IEC 81400-4 [7] are based on an intensive exchange of experience between all parties involved. The introduction to this standard points out that the operation and loading of a wind turbine gearbox is unlike most other industrial gear applications. The intent of this standard is to describe the differences. A speed-increasing transmission and the lack of a stable foundation are

the most striking distinctions exhibited by wind turbine gearboxes. The standard describes both the requirements for the gearbox as a whole and the requirements for the individual elements, e.g. toothings, bearings, shafts etc. The load capacity of spur and helical gears is generally verified on the basis of ISO 6336 or AGMA 6006 [2]. The load capacity of bearings is proven by means of the “basic dynamic load rating” or “modified rating life” approaches described in ISO 281. In this regard, the cases of bearing damage occurring increasingly in recent years have also shown that these procedures are by no means suited as lifetime analyses, but can only be meaningfully used for preliminary design. For this reason, the later wind energy standards provide for the “advanced contact analysis” as per ISO 281 Annex B or according to the methods of the bearing manufacturers as a lifetime analysis with due consideration of the maximum contact stress. In addition, the wind energy standards contain bearing selection tables, since many of the cases of bearing damage mentioned above may be ascribed to an incorrect choice of bearing.

In addition to the computational verification of the load capacities and lifetimes of the individual components of a gearbox, the newer standards also prescribe a functional verification in the form of practical demonstrations and tests. Here a distinction is made between prototype trials, field tests and series tests. The aim of the prototype trial is to examine whether the assumptions and boundary conditions that were set in the design phase are indeed correct. In the field test of the wind turbine, the load assumptions are checked and the system response is studied. Finally, the series tests are intended to demonstrate that the series-manufactured gearboxes comply with the performance standard set by the successfully tested prototype.

The drive train of a wind turbine must be looked at as a complex assembly. Its operational reliability can no longer be assessed solely by verifying the strength of individual components. Hence dynamic simulation of the drive train will become even more important in order to obtain a reliable prediction of the individual components loading situations.

5.4 Turbine and project certification practice

5.4.1 Introduction

Certification of wind turbines has a history of more than thirty years. The aim of certification is the minimisation of risks and building up confidence to investors, insurances, operators and authorities by a third party assessment.

According to the international standard ISO/IEC 17000, certification is the confirmation of compliance of a product or service with defined requirements. International standards and guidelines are used to carry out Type Certification and Project Certification in the wind turbine branch. The most important guidelines for certification of onshore and offshore wind turbines and wind farms are IEC WT 01 published by the IEC in April 2001 and the Guideline for the Certification of Wind Turbines, 2003 with Supplement 2004. Recently nearly all parts of IEC WT 01 have been subject to changes and it will shortly be replaced by IEC TS 61400-22 [34].

5.4.2 Wind turbine type certification

Type Certification applies in general to a generic wind turbine and is not related to a certain site. To obtain a Type Certificate the modules as shown in Figure 5.3 are to be carried out.

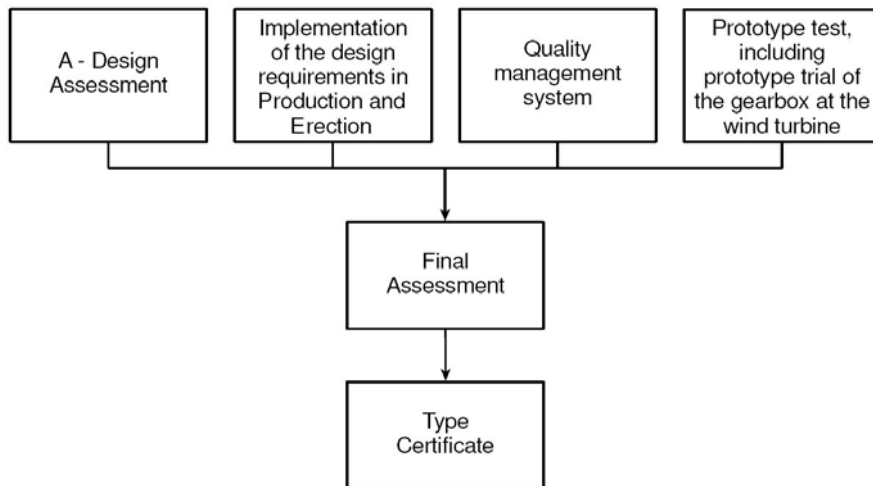

Figure 5.3: Modules of Type Certification

The Design Assessment according to GL’s wind guideline consists of a complete examination of the design analysis with material and component tests. It is completed with the commissioning witnessing. According to GL’s wind guideline the following documents in the form of specifications, calculations, drawings, descriptions and / or parts lists are to be assessed:

- control and safety concept
- load case definitions / load assumptions
- safety system
- rotor blades and blade test reports
- mechanical structures including nacelle housing and spinner
- machinery components (including prototype test of the gearbox on an adequate test bench)
- electrical installations, including lightning protection
- tower and, optionally, foundation
- manuals for erection, commissioning, operating and maintenance
- other optional items like personnel safety

The load case definitions and the load assumptions / load calculations can be performed according to the International Standards IEC 61400-1, second edition or IEC 61400–1, third edition or GL’s wind guideline.

Implementation of the design-related requirements in Production and Erection (IPE) shall ensure that the requirements set forth in the technical documentation of the components are observed and implemented in production and erection of the wind turbine. This is shown by the manufacturer of the components and the manufacturer of the wind turbine to the certification body.

During the module “Quality management system” it is shown that the designer and manufacturer meet the requirements of ISO 9001 with regard to the design and manufacturing process.

Within the scope of Prototype Testing measurements of the power curve, noise emission and electrical properties as well as a test of wind turbine behaviour and load measurements are carried out. Furthermore the prototype of the gearbox is to be tested on the wind turbine. Prototype measurements shall be carried out by test institutes accredited according to EN 45001 (ISO17025). The certification body reviews the analysis of measured data and compares these with the design loads. Depending on the results the comparison leads to the validation of the design calculation loads for the Type Certification. As a minimum, load measurements should be carried out at the following locations:

- Blade root, flap-wise, lead-lag, torsion (preferably all blades)

- Rotor shaft, bending, torque (rotating)
- Tower top, bending, torque
- Tower base, bending (two directions)

Besides, all relevant meteorological data and turbine operational data shall be measured according to IEC standard. The load measurement program shall be based on and consist of load situations that are as close as practically possible to the design load cases defined and used in the general design assessment of the wind turbine. The measurements shall include all normal and abnormal operating conditions such as the braking performance (e.g. emergency shut down, loss of grid, protection system fault, etc.), the yaw behaviour and stand still/idling at high winds. Typical operational behaviour throughout the design wind speed range shall be covered by the measurements. In case of differences to the design assessment occur, additional load calculations based on the dynamics and wind conditions of the turbine under test may be required to allow for comparison analysis of measured and calculated data.

5.4.3 Project Certification

Project Certification is carried out for wind turbines having successfully received Type Certification and for locations for which the necessary data is available. Basically, Project Certification is intended for projects covering more than one single wind turbine such as wind farms onshore and offshore. This certification covers the aspects of assessing site conditions and suitability of the wind turbine for a given site. The individual modules are shown in Figure 5.4.

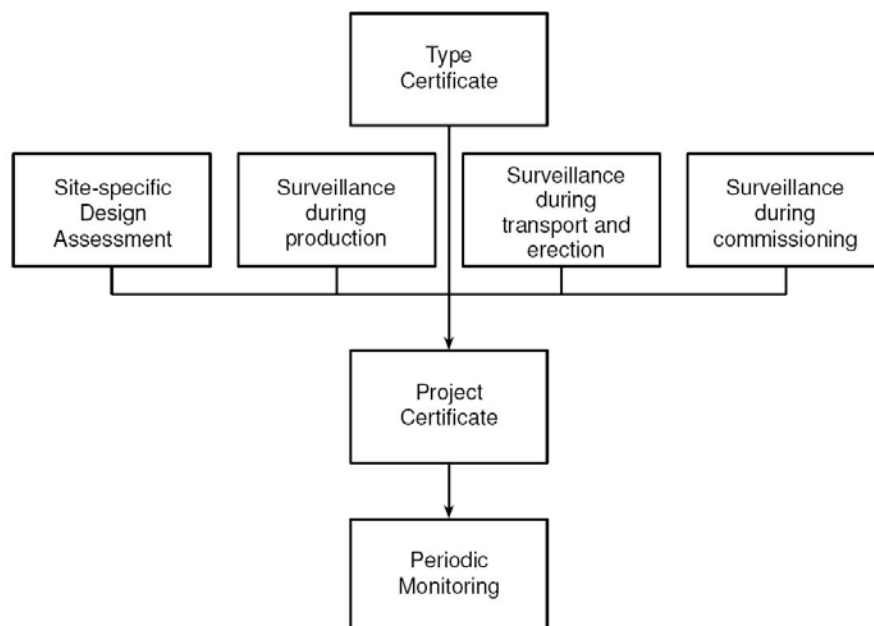

Figure 5.4: Modules of Project Certification

Within the Site Assessment, the site conditions will be checked and compared to the parameters used for the design assessment of the generic wind turbine during the Type Certification. In case that the conditions at the site are not covered by the design parameters, a design assessment will be performed applying the site-specific conditions in order to show the suitability for the wind turbine in question.

Prior to the manufacturing surveillance, certain Quality Management (QM) requirements shall be met by the manufacturer. The QM system should be certified to comply with ISO 9001; otherwise the QM measures can be assessed by the certification body. The surveillance during production usually covers inspection and testing of materials and components, scrutiny of QM records (test certificates, reports), surveillance of production, inspection of the corrosion protection and of the electrical power system.

The surveillance of installation at the site of erection shall be restricted to the important steps during support structure manufacturing and erection work. An identification and inspection of component manufacturing, transportation, on site work and installation shall be carried out before start-up of the wind turbine. Commissioning witnessing forms an integral part of the certification process between the construction phase and the operation phase. During commissioning, which is performed according to the previously approved procedures all components related to operation and safety are being inspected and / or tested.

Periodic Monitoring is necessary to maintain the validity of the Project Certificate and is carried out in regular intervals of e.g. two years.

6. Conclusions and recommendations for ProTest project

The design process of wind turbine components is based on aeroelastic calculations of various DLCs that are described in standards and guidelines like the IEC 61400-1 or the GL guidelines for the Certification of wind turbines. These wind turbine standards have been developed to ensure the engineering integrity of wind turbines. Recently it became obvious that these DLCs are not sufficient for the design of machinery components, especially the drive train, but also for the pitch and yaw systems. Especially for the drive train an additional standard (IEC 61400-4) is currently under development. IEC 61400-4 is a good starting point to define specific DLCs, but no detailed list of DLCs is provided. At present it cannot be concluded whether the DLCs specified in the wind turbine standards are specific enough for the drive train components. It can also not be evaluated whether the DLCs defined with the assistance of IEC 61400-4 are relevant and/or sufficient for calculating the design loads of drive train components.

Therefore, the PROTEST project will evaluate whether the currently considered load cases are sufficient for the drive train, pitch and yaw system, or which additional DLCs have to be considered.

It is also concluded that the state-of-the-art aeroelastic simulation codes use a simplified representation of the machinery components, esp. the drive train, that result in neglecting the interactions of the components. Instead, at present only the GL guideline requires consideration of the internal component dynamics by drive train resonance analyses to identify possible resonances. But the results are not linked to wind turbine loading. To overcome the shortcomings of this simulation approach, advanced wind turbine simulation codes could consider more detailed models of the drive train components also for aeroelastic simulations in the time domain. It cannot yet be concluded whether this approach would be beneficial and which modelling details should be considered.

It will be evaluated within the PROTEST project which model details should be included in such simulation codes and what kind of benefit those additional details will have in the design process of wind turbine components.

For the calculation of the pitch system design loads, combined analytical and empirical models are currently used to transfer the global loads to loads at the pitch system. These models are a weak point in the design process especially for future large turbines with relatively flexible pitch bearings. The PROTEST project will analyse how these methods could be standardised. For calculating the design loads of the yaw system only rough models are currently used. Therefore, the PROTEST project should also analyse how the load is transferred from the rotor through the drive train and nacelle to the yaw system and a method should be formulated for this approach.

For load measurements, performed to support the design process, and for certification various MLCs are defined in guidelines and standards, esp. IEC/TS 61400-13. At present measurement campaigns are used to validate the global design loads with measurement loads. Similar to the DLCs, it is not yet clear whether the provided MLCs are sufficient to validate the design loads of all the wind turbine components. Moreover, the guidelines and standards define the measurement campaign in detail, but no procedure is given about how to validate the global design loads with the measured loads. Furthermore, at present there are no guidelines or standards to define a measurement campaign for wind turbine components. Since no procedure is given for the validation of the global loads, this lack of information is even more relevant for the validation of component loads.

Therefore, the PROTEST project intends to develop procedures for performing such a measurement campaign and for validating the loads, used for the component design, with the component measurement data.

More attention should be given to setting up a formalism between OEM, end user and component manufacturer to exchange loadability data on populations of, for example, gearboxes and to perform proper root cause analyses (RCA's) per failure case. Every wind turbine operating in the field under "normal" conditions is a test bench. By defining a set of data which is available to the different parties, failure mechanisms, causes and influencing parameters can be detected consistently and faster and they can be taken into account in the design phase.

7. Outlook and Proposal for improved design, measurement and certification approaches

7.1 General

When looking at the future prospects for the design and development procedures for mechanical components, it is the expectation of the authors that it will follow a similar route as the design and development of rotor blades over the last 20 years. The design process for rotor blades (and also for the tower) is critical for safety: failures will lead to unsafe situations. Failures of other mechanical systems however are mainly critical for reliability: failures will lead to standstill and economic losses only. Therefore in the past, safety standards have been developed for wind turbines [28] together with technical specifications on how to carry out full scale blade testing [31] and prototype measurements [31] in order to minimise the number of blade failures.

Recently, it has been recognised that not only safety is relevant for wind turbine engineering but also reliability. As an example, the safety standard IEC 61400-1 "*Wind Turbine Generator Systems - Part 1: Safety Requirements*" [33] was updated into a design standard entitled IEC 61400-1 "*Wind Turbine Generator Systems - Part 1: Design Requirements*" [27]. This standard clearly specifies which load cases should be considered and what input parameters should be chosen to determine the global design loads. The standard also gives guidance on what models for e.g. wind simulations should be used. The standard is less specific for the design of mechanical components.

For the development of rotor blades, the design and development procedure is briefly as follows.

1. Design calculations are being made to determine the ultimate and fatigue loads on these components and to assess the strength of the components. The blade response can be simulated rather accurately using beam models (although for larger blades there is still research on-going) Important blade properties for the wind turbine overall behaviour are identified first and are incorporated in the simulation tools. From Chapter 2 it is concluded that for mechanical components such an approach is not common practice. The dynamic properties of the individual components are hardly known a priori and can thus not be incorporated in the simulation tools. For rotor blades, the responses (mainly time series of loads and stresses) can be used to verify the strength at many spots in the blade. For mechanical components it is common practice that responses from simulation tools are handed over from the turbine designer to the component designer, but only for some interfaces.
2. A test load spectrum, based on the responses of the simulation tools, is used for testing rotor blades full scale in a laboratory environment. If vulnerable spots show up, the blades will be improved accordingly. Furthermore, the laboratory tests are being used to assess the design properties like natural frequencies, mode shapes, etc. It is common practice to apply multi axial loads during the full scale tests at different positions along the blade length in order to approach the real situation as good as possible. For other mechanical components, such laboratory tests to verify the strength and determine mechanical properties are hardly being carried out.
3. Prototype measurements are being carried out, among others to assess if the actual loads on the rotor blades are more benign than the design loads. Guidelines for doing such measurements are described in large detail in [31]. From Chapter 4 it is concluded that procedures for comparing the measured blade loads with the design loads are not clearly specified which weakens the role of measurements especially during the certification process of turbines and rotor blades. It was also concluded in Chapter 4 that measurement procedures for mechanical components are not available.
4. It is also concluded in Chapter 4 that most manufacturers use the measurements for verifying the correctness of their design models and to determine the input parameters of their model. Clear procedures for doing this are not described and probably differ from designer to designer. Once the design models are verified and tuned they can be used for the design of the series production.

This design and development process for rotor blades is schematically shown in Figure 7.1. The process for designing and developing other mechanical components is sketched in Figure 7.2.

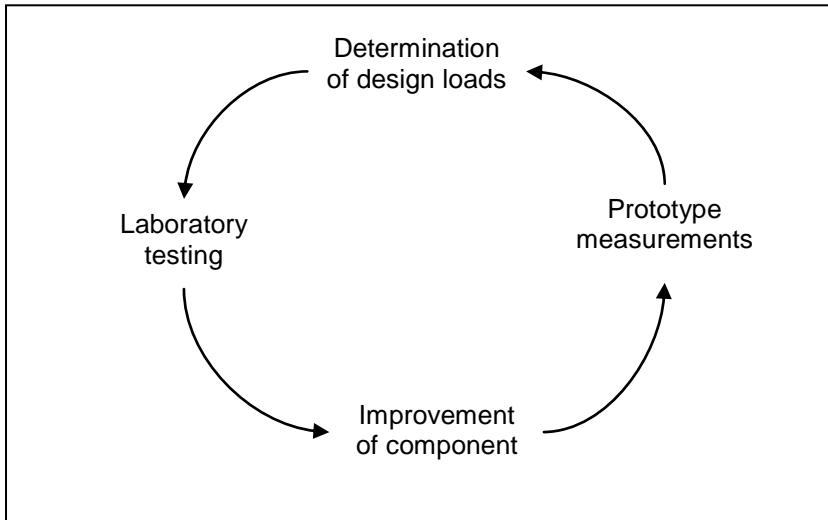

Figure 7.1: Design and development process of rotor blades

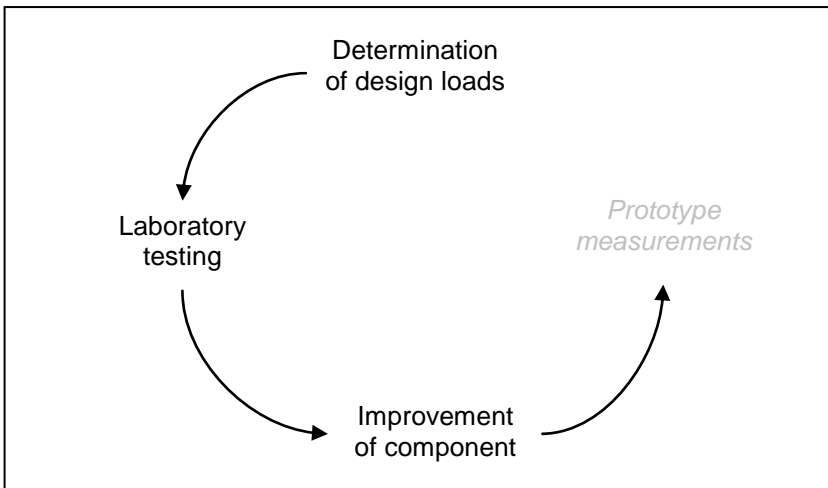

Figure 7.2: Design and development process of other mechanical components

From safety point of view, it can be justified why the standards and technical specifications focus on assessing the strength of rotor blades and towers. It is the authors believe that if wind energy becomes a mature branch of industry, improving turbine reliability and thus the economics will become as important as safe operation. It is therefore likely that the design and development process of mechanical components will undergo a similar improvement route as the process for rotor blades.

7.2 Improved design approach

If the blade design is taken as a reference, and based on the findings of mainly Chapter 2, it is concluded that the design approach for mechanical components can be improved in the following ways.

- The list of design load cases as presented in [27] has been developed to determine the global loads acting on the rotor and tower mainly. It should be assessed if the prescribed design load cases together with the additional load cases as specified for instance in [2], [7], [32] are also representative for the design of mechanical components like the drive train, pitch system, and yaw system. E.g. it is unclear if all design drivers for these components are covered by the load cases.

It is important to make an inventory of design drivers and possible failure modes at an early stage of the component design and to develop models which cover these design drivers. Once such an inventory is made it can be used to assess the adequacy of the list with design load cases. For the development of the list of load cases in [27], the design drivers fatigue and ultimate strength have been considered only. These design drivers apply to “load carrying components” mainly. For gearboxes, couplings, bearings, etc. other design drivers will be of relevance and probably require other models and load cases.

- For rotor blades, it is common practice to derive dynamic properties for wind turbine simulation tools from detailed models (e.g. Finite Element Models). During the wind turbine modelling process, effort is put in making sure that properties like natural frequencies, material damping, and mode shapes are tuned to the actual values. Laboratory tests and even in-situ test may even support in obtaining the correct properties. In the design process for mechanical components, this is at present not common practice. It is foreseen however (and recommended) that more and more e.g. multi body simulations of mechanical components will be made to determine which degrees of freedom (and corresponding component properties) are needed to develop a simplified component model that can be implemented in the wind turbine simulation tools.

7.3 Improved measurement procedures

Currently, the measurement procedures for measuring loads in rotor blades are prescribed in the IEC TS 61400-13 [33] and includes strict guidelines for analysing and reporting the data. The use of the reported measurement results however is unclear in the entire design and development process. The “raw measurement data” however like time series and 10-minutes statistics, are being used by the turbine designers to verify the models.

It is therefore recommended that measurement procedures will be developed for mechanical components too. As opposed to the guidelines in [33], more emphasis should be put on the use of the measured data in the design process. The guidelines should reflect much more the actual situation, meaning that the measured data are being used for model validation and quantifying the input parameters and component properties. If the measurement campaigns are going to be used for model validation, this implies that the details of the measurement campaign will become dependent on the design model: the more accurate and detailed the model, the more detailed the measurement campaign should be.

Probably the measurement load cases as specified in [33] are not adequate for all mechanical components, but this needs to be assessed. The design load cases should cover those situations needed to verify the model and to quantify the component properties. If, for instance, the design driver of a mechanical component is a specific ultimate load caused by a single load case, it is not necessary to measure all fatigue load cases.

Moreover, the measurement procedures (among others, the measurement frequencies and signals) as specified in [33], need to be reconsidered. Probably, most of the mechanical components will have different properties which require different signals, different sensors, different measurement frequencies, and different processing techniques.

Finally, measurements can be used for quantifying loads and responses in those situations where the models are not reliable. During such measurements, phenomena may show up which have not been considered at all during the design and which may give reason to modify and improve the design models.

The authors foresee that the improved measurement procedures will include recommendations how to develop a suitable measurement campaign for a certain mechanical component, rather than prescribing in large detail how to carry out the measurements exactly. The development of this procedure is of course the main challenge of this PROTEST project.

7.4 Improvement of standards and certification

In addition to the current guidelines, risk-based guidelines will come up in the long term. The failure probability of each component will be defined based on the components significance for the entire

wind turbine system. In those guidelines the topics redundancy and maintainability will come to the fore. For example, subcomponents that can be maintained and replaced easily and are redundant in the overall system will be dimensioned on a lower level than main components that are critical for the safety and economic efficiency of the wind turbine.

Design methods that are developed specifically for the wind turbine industry and globally accepted will be used and described by future guidelines and standards. New standards and guidelines will differentiate in the size of the wind turbines for the design and certification process. The standards and guidelines will also define different design criteria for onshore and offshore wind turbines.

Material properties will be determined based on tests more often. Strain based S-N curves will be used for future common fatigue calculations. Furthermore, methods for fatigue calculations that consider the plane state of stress will be used.

The future certification process will focus more on supervising the quality of the manufacturing process.

7.5 *Improvement of data exchange*

After validation of the prototype turbine it is necessary that a certain minimum of data flow from wind farm owner to wind turbine manufacturer to component (for example gearbox) manufacturer. This is lacking at this moment. Setting up such a data exchange would allow for optimizing service strategies and improving designs more rapidly and consistently since fundamental lessons can be learned from field failures if load data for the specific failures are available (for example: loadability of components can be derived from field failures). Also time to failure (MBTF) and time to repair (MTTR) can be linked to certain operating conditions and for specific root causes. Doing so, optimal service strategies can be derived and implemented to optimize wind turbine availability and minimize service costs. Such approach require a clear and consistent exchange of load data from end-user via wind turbine manufacturer to component manufacturer and a similar feedback on failure analysis from the component manufacturing side to the wind farm owner. Such approaches are currently standard in other applications like for example automotive where component manufacturers (for example suspension manufacturers) work in close collaboration with car manufacturers by exchanging high quality data to optimize the products.

8. References

1. Allianz Zentrum fuer Technik GmbH: Anforderungen an Condition Monitoring Systeme fuer Windenergieanlagen, Report No. 03.01.068, 2003
2. ANSI/AGMA/AWEA 6006-A03: Standard for Design and Specification of Gearboxes for Wind turbines (2004)
3. Bossanyi, E. et al: The Effect of Gearbox Flexibility on Wind Turbine Dynamics, Proceedings of the EWEC 2008, Brussels, April 2008
4. BTM Consult: International Wind Energy Development; World Market Update 2005, Denmark, March 2006.
5. BTM Consult: International Wind Energy Development; World Market Update 2007, Denmark, March 2008.
6. DiBT: "Richtlinie für Windenergieanlagen, Einwirkungen und Standsicherheitsnachweise für Turm und Gründungen", Berlin, March 2004
7. DIN EN ISO/IEC 81400-4: Wind turbine generator systems - Part 4 Gearboxes for turbines from 40 kW to 2 MW and larger (draft)
8. DNV/Risø: Guidelines for the Design of Wind Turbines, Second Edition. 2002.
9. Dombrowski, A.; Ristow, M.; Subramanian, S.: On the Fatigue Life of Wind Turbine Structural Components; Germanischer Lloyd 2006
10. Douvikas, D., Foussekis, D., Glinou, G., Mouzakis, F., Fragoulis, A.: Investigation of Design Aspects and Design Options for Wind Turbines Operating in Complex Terrain Environments (COMTERID), JOR3-CT95-0033, Final Report, 1998
11. DS 472, 1. Udgave 1992 plus Addendum DS 472 Til 1: 1996: "Code of Practice for Loads and Safety of Wind Turbine Constructions"
12. Durstewitz, M. et al: Wind Energy Report Germany 2001; Annual Evaluation of WMEP, ISET, Germany 2002 (and reports of the following years)
13. Dutch Wind Work Shops, held at ECN 11&12 October 2006
14. Echavarria, E., et al: How Has Reliability of Technology Developed Through Time?, EWEC 2007
15. Energie- og Miljødata (EMD): database with energy production figures, incidents and accidents.
16. Gasch, R., Tvele, J.: Windkraftanlagen - Grundlagen, Entwurf, Planung und Betrieb 4. Auflage, Berlin 2005
17. Germanischer Lloyd: Guidelines for the Certification of Wind Turbines, 2003 (with Supplement 2004)
18. Germanischer Lloyd, Rules and Guidelines, IV: Industrial Services; 4: Guideline for the certification of condition monitoring systems for wind turbines, Edition 2007
19. Germanischer Lloyd. IV Rules and Guidelines Industrial Services - Part 1: Guidelines for the certification of Wind Turbines, Edition 2003

20. Global Wind Energy Council, <http://www.gwec.net>, March 2009
21. Gryzbowski, R. et al: Gearboxes for Wind Turbines in the Light of National and International standards, Germanischer Lloyd - Beaufort6, Edition 1/2008
22. Hahn, B. et al: Improving Wind Turbine Availability by Reliability Based Maintenance, DEWEK, Bremen, 2006
23. Hahn, B. et al: Reliability of Wind Turbines, ISET, Kassel
24. Hahn, B.: Zuverlässigkeit, Wartung und Betriebskosten von Windkraftanlagen, Auswertung des wissenschaftlichen Mess- und Evaluierungsprogramms (WMEP), Institut für Solare Energieversorgungstechnik (ISET), Kassel 2003
25. Hansen, Martin O.L.: Aerodynamics of Wind Turbines. London, James and James, 2000
26. Hauptmann, S. et al: Advanced Drive Train Modeling in a Virtual Wind Turbine Using the Multibody Simulation Code SIMPACK, EWEC 2007, Milan, 2007
27. IEC 61400-1 Wind turbine generator systems - Part 1: Design requirements, third edition, August 2005
28. IEC 61400-1: Wind turbine generator systems-Part 1: Safety requirements, second ed., February 1999
29. IEC 61400-12-1: Wind turbines, Part 12-1: Power performance measurements of electricity producing wind turbines, (1st Ed. 2005).
30. IEC 61400-21: 2008, Edition 2, Wind Turbines - Part 21: Measurement and assessment of Power quality characteristics of grid connected wind turbines
31. IEC 61400-23: Wind Turbine Generator Systems - Part 23: Full-scale structural testing of rotor blades
32. IEC 61400-4: Wind turbines - Design and specification for gearboxes (in preparation)
33. IEC TS 61400-13: Wind turbine generator systems, Part 13 - Measurement of mechanical loads (1st Ed. 2001).
34. IEC TS 61400-22: Conformity Testing and Certification of Wind Turbines, First , 2008 (CDV)
35. IEC WT 01: IEC System for Conformity Testing and Certification of Wind Turbines, Rules and Procedures, 2001-04
36. ISO 281, second edition: Rolling bearings - Dynamic load ratings and rating life (2007)
37. ISO 6336: Calculation of load capacity of spur and helical gears (2006)
38. Kochmann, M., Ristow, M.: Efficient Modelling of the Drive Train Dynamics in Wind Turbines, DEWEK 2008, conference proceedings
39. Manjock, A., Franke, J.-B.: Load Assumptions for the Design of Electro Mechanic Pitch Systems, Germanischer Lloyd, Proceedings of The European Wind Energy Conference EWEC2007, Milan, May 7-10 2007
40. Manwell, J. F., McGowan, J. G. and Rogers, A.L.: Wind Energy Explained. Hoboken, John Wiley and Sons, LTD, 2002

41. McVittie, D.: Wind Turbine Gearbox Reliability, GEAR ENGINEERS, INC. SEATTLE, WA
42. Musial, W., Butterfield, S.: Improving Wind Turbine Gearbox Reliability. National Renewal Energy Laboratory, Boulder, CO USA. May 2007
43. Papadopoulos, P., Tentzerakis, S., Binopoulos, E., Mouzakis, F., Foussekis, D.: Integrated mechanical load and electrical monitoring on wind turbine drive trains, EWEC 2008, Brussels, Belgium, 31st March - 3rd April 2008
44. Pedersen, T.F. et al: Accurate Wind Speed Measurements in Wind Energy (ACCUWIND), NNE5-2001-00831, Final Report, RISOE-R-1563, 2006
45. Peeters, J.: Simulation of dynamic drive train loads in a wind turbine, PhD dissertation, Heverlee (Belgium), June 2006
46. Peeters, J., Vandepitte, D., Sas, D.: Internal dynamics of an integrated drive train in a wind turbine, Proceedings of The European Wind Energy Conference EWEC2004, London, UK, 2004 November 22-25
47. Platts PowerVision and EWEA: Wind energy leads EU power installations in 2007, but national growth is inconsistent. Press release 2008
48. Rasmussen, F., Thomsen, K., Larsen, T. J.: The Bearing Problem Revisited. Risoe - Aeroelastic Design Wind Energy Department, Roskilde, Denmark, 2004
49. Ribrant, J. et al: Survey of Failures in Wind Power Systems With Focus on Swedish Wind Power Plants During 1997-2005, IEEE
50. Ristow, M.: Fatigue assessment of welded structures in wind turbines; Germanischer Lloyd 2008
51. SAMTECH, BOSCH-REXROTH: Concept report simulation platform and reference gearbox measurements, UPWIND Deliverable report (1B2.a.1), 2007
52. Schepers, J.G et al: Verification of European wind turbine design codes, VEWTDC: final report, ECN-C--01-055, April 2002
53. Seeliger, A et al: Combination of Multi Body System Simulation, Electrical Simulation and Condition Monitoring - A powerful research development; Proceedings of The European Wind Energy Conference EWEC2006, Athens, Greece, 27 February - 2 March 2006
54. Söker, H. et al: A guide to load validation, DEWEK 2006
55. Strategic Research Agenda: Market Deployment Strategy, Technology Platform Wind, 2008
56. Tavner, P.: The Reliability of Different Wind Turbine Concepts, with Relevance to Offshore Application. New & Renewable Energy Group, School of Engineering, United Kingdom. EWEC Conference, 2008
57. Vionis, P., Lekou, D., Mouzakis, F.: Adaptation of Existing wind turbines for operation on high wind speed complex terrain sites ; kWh cost reduction (ADAPTURB), JOR3-CT98-0251, Final Report, 2003
58. Vionis, P. et al: Development of a MW scale wind turbine for high wind complex terrain sites; the MEGAWIND project, EWEC 2006, Athens, Greece, February 2006.
59. Wiggelinkhuizen, E. et al: CONMOW: Condition Monitoring Offshore Wind Turbines, EWEC 2007.

60. Windenergie XIX: Praxisergebnisse 2006; Landwirtschaftskammer Schleswig Holstein
61. Windenergie XVII: Praxisergebnisse 2004; Landwirtschaftskammer Schleswig Holstein
62. Windenergie XVIII: Praxisergebnisse 2005; Landwirtschaftskammer Schleswig Holstein
63. Windenergie XX: Praxisergebnisse 2007; Landwirtschaftskammer Schleswig Holstein
64. Woebbeking, M.: The latest news for certification of Wind Turbines and Wind Farms - Onshore and Offshore; Germanischer Lloyd 2008
65. Woebbeking, M.: Type and Project Certification; Germanischer Lloyd 2007
66. Zhang, S. et al: Problems Experienced with Operating Wind Farms in China, 2005 IEEE/PES Transmission and Distribution Conference & Exhibition, China

Appendix A

Evaluation of component failures and associated O&M costs

A 1: Wind turbine technical availability

To compare the quality of wind turbines, they are usually rated using the technical availability. Technical availability represents the percentage of time a turbine is technically available. This means that the turbine is either in production mode or in idling mode because of lack of wind or too strong wind. If a turbine is not technically available it is in downtime caused by shutdown or breakdown. Shutdown time covers the time a turbine is down not because of malfunction but because of maintenance work. Breakdown time is usually caused by faulty or damaged wind turbine components and is therefore related to the wind turbine technology. The downtime can be given in hours or as a percentage. In addition, auxiliary downtime occurs which is not directly caused by the turbine's condition, e.g. grid loss, auxiliary works and visit, etc. If the downtime and auxiliary time in percent is subtracted from 100% the result one gets is the technical availability. The technical availability is in particular relevant to evaluate the energy yield of wind turbines and gives an indication about the turbine economics.

Nevertheless the technical availability does not give any information about the reliability of the components that are installed in a wind turbine. When discussing components it is important to understand that there is no direct relation between breakdown time and resulting costs. If a turbine breakdown is caused by a gearbox failure that needs an exchange of the entire gearbox there are much higher costs than a breakdown caused by a failure of an electrical component, even if the breakdown time is just as long for both failures. More information about failure rates of main components and the costs associated with those failures can be found in sections A3 and A4 respectively.

Looking at the wind turbine as an entire system, one can see that the average technical availability for wind turbines in Europe is high, around 98% [23]. This means that wind turbines are down because of shutdown or breakdown for only about one week each year. This includes all installed turbines, starting from 20 year old stall controlled turbines with a rated power of less than 150 kW up to the actual pitch controlled turbines with more than 90m rotor diameter and more than 2MW rated power.

year of evaluation	shutdown time [%]	breakdown time [%]	technical availability [%]
1993	0,15	1,47	98,4
1994	0,17	0,88	99
1995	0,3	0,51	99,2
1996	0,29	0,38	99,3
1997	0,03	0,68	99,2
1998	0,17	0,94	98,9
1999	0,35	0,96	98,7
2000	0,36	1,21	98,4
2001	0,3	0,88	98,8
2002	0,51	1,35	98,1
2003	0,31	0,91	98,8
2004	0,38	1,05	98,6
2005	0,35	1,06	98,6
2006	0,35	1,02	98,6
2007	0,29	1,55	98,2

Table A-1: Down time and technical availability over 15 years [63]

To classify the actual wind turbine availability, Table 6.1 shows the trend of the shutdown time, breakdown time and the technical availability over the last 15 years. The data relies on analyses that are performed for Schleswig-Holstein in Germany [63].

The most interesting information can be found in the column “breakdown time”. While the shutdown time was decreasing, the breakdown time was increasing in 2007 compared to the years before. This results in a more or less constant technical availability. It seems that the wind turbine technology is becoming less reliable.

To understand the reasons for this trend, Table 6.2 should be considered. Modern turbines are much larger than older turbines are. In Table 6.2 the downtimes and the technical availability are shown over rated power for the year 2007. The table shows that the fast growth in rated power of newer turbines could be the reason for the higher breakdown time that came up in the last years.

Rated power [kW]	shutdown time [%]	breakdown time [%]	technical availability [%]
0 - 150 kW	0,07	0,58	99,3
151 - 300 kW	0,24	0,75	99
301 - 750 kW	0,28	0,99	98,7
more than 750 kW	0,42	3,08	96,5

Table A-2: Down time and technical availability over rated power for 2007 [63]

Table A-2 shows that the breakdown time is much more important for large turbines than for smaller ones. Especially the modern turbines with more than 750kW do not reach a technical availability as the averaged 98%. It is also shown that the decreased technical availability is caused by, on the one hand side, on an increasing shutdown time, but even more important on an increase in breakdown time. This indicates that also the failure rate of large turbines could be higher than for smaller turbines.

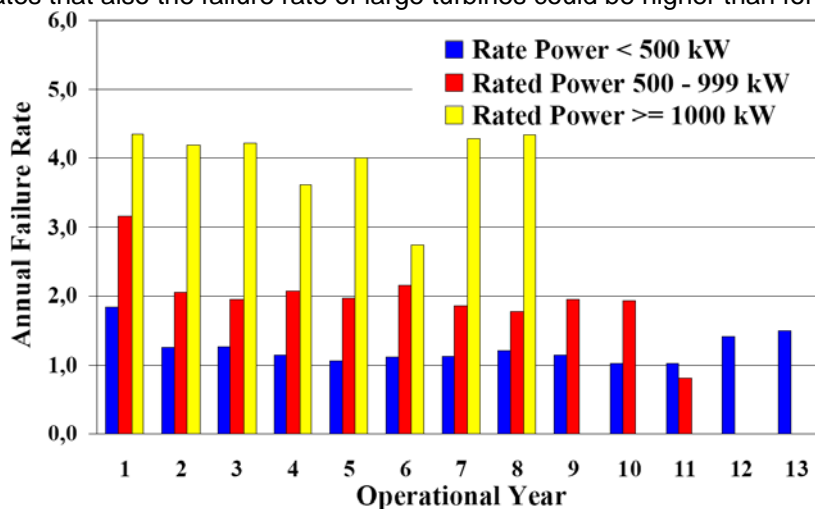

Figure A.1: Failure rates of wind turbines categorized by rated power [24]

Table A-1 shows failure rates of wind turbines not only depending on their operational age, but also depending on the rated power. In general it can be seen that the failure rates for the turbines with a rated power of about less than 1MW are decreasing with time. In the first year there is a short period of a larger number of early failures that is followed by a longer period of fewer random failures. But for the annual failure rate of larger turbines belonging to the mega-watt class this is not the case. Those turbines entered the market in a significant number about 8 years ago and have a long period of a high failure rate that has not yet become stable. This clearly shows that there is a need of increasing the reliability of wind turbines in the MW class.

	rated power [MW]	number of considered turbines	averaged age [month]	shutdown time [%]	breakdown time [%]	downtime [%]	technical availability [%]	
Nordex N52/54	1	6	131	0,22	9,16	9,37	90,63	
AN Bonus 1 MW/54	1	7	98	0,57	3,05	3,62	96,38	
AN-Bonus 1,3MW/62	1,3	6	92	0,51	1,03	1,55	98,45	
Südwind S70	1,5	3	76	0,31	6,61	6,92	93,08	
GE / TW 1,5s	1,5	3	92	0,20	3,01	3,21	96,79	
Vestas V66/1,65	1,65	10	83	0,43	4,06	4,49	95,51	
Vestas V80/2,0	2	5	60	0,00	4,21	4,21	95,79	
<i>Enercon E66/18.70</i>	<i>1,8</i>	<i>15</i>	<i>64</i>	<i>0,63</i>	<i>0,11</i>	<i>0,74</i>	<i>99,26</i>	<i>direct drive</i>
average	1,51	55	84	0,43	3,18	3,61	96,39	
average (w/o direct drive)	1,41	40	91	0,36	4,33	4,68	95,32	

Table A-3: Technical availability of various wind turbines [63]

Since different wind turbine manufactures rely on different drive train and control concepts and have different design philosophies, it is interesting to know, if there are major differences in the technical availability between the manufactures. Table A-3 shows the technical availability of various wind turbines. All listed turbines have a rated power between one and two mega-watts with an average of 1,5MW. It is also mentioned how many turbines were considered for the analysis and how old these turbines are in average. Since the data for some types of turbines only rely on 3 turbines it is obvious that this data has to be treated with care.

The table shows that most of the mentioned turbines have a technical availability of less than 97%. One exception can be found at the Enercon E66. This turbine has a much higher availability of about 99,26%. This turbine uses a direct drive concept which is totally different to the concept used for the other turbines.

It can be concluded that there is a need in improvement of wind turbine reliability to achieve a higher availability, although a present average availability of about 98% is high. However, especially large turbines of the mega-watt class often have a failure rate that is not acceptable. As future plans are concentrating on offshore use of mega-watt wind turbines, a major loss of availability has to be expected that is caused by a poor accessibility.

A 2: Field performance and wind turbine inspection

Maintenance and repair concepts

The technical availability of wind turbines is not only affected by the reliability of the wind turbine components but also on wind turbine inspection and service. Different concepts for maintenance and repair can be found for different wind turbines components.

Break-down-strategy: Only the legally prescribed inspections are performed. The components are usually used for their entire lifetime. After the component has failed, it is replaced as necessary.

Time-base maintenance: Maintenance is performed in fixed time cycles. For each component a theoretical lifetime is defined. If the predefined lifetime has expired, the component is replaced, without considering the real deterioration of the component.

Condition-based maintenance: The condition of the component for maintenance purposes is taken into account; a component replacement or maintenance is only done when a component failure has to be expected. This concept is only applicable for components that are equipped with a condition monitoring system.

Reliability centred maintenance: An additional consideration of other target values like costs and the technical availability of the entire wind turbine are taken into account for the predefinition of the maintenance cycles.

Risk-based maintenance: Additional consideration of the risk of the component failure for other parts of the turbine and economic penalty due to downtime.

Most of the wind turbines use the concept of time-based maintenance rates for the majority of the components, but at present more and more condition based maintenance is introduced for main components like the gearbox e.g. of larger turbines. Also the use of reliability centred maintenance for wind turbines is currently under investigation.

The motivation for wind turbine inspection and maintenance is to maximise the technical availability, durability, and therefore the resulting economical efficiency. In detail, the focus is on the following tasks:

- A failure-free and optimal operation.
- Occurring failures are corrected immediately.
- A fast and systematically detection of parts which need to be replaced or repaired.
- Preventive maintenance to avoid breakdown or damage.
- Replacement of wear parts.
- Execution of required repairs.

Wind turbines are visited at regular intervals, usually semi-annually, for inspection and maintenance. The actual state of the wind turbine is determined, compared to the target state and evaluated. Based on the results from evaluation, the consequences have to be drawn, such as repair, exchange, etc. Therefore, also the data gained from operating surveillance systems, such as supervisory control and data acquisition (SCADA), and from online condition monitoring systems (CMS), if available.

Instructions and recommendations for inspection and maintenance are specified by the wind turbine manufacturer in the specification sheet.

The most important issues for inspection and maintenance are:

- Check of all wind turbine components including the tower.
- Check of all screw moments and retightening as specified in the specification sheet.
- Check of oil-levels and refilling of oil.
- Analyses of a gearbox lubricant sample.
- Oil change

- Grease of the relevant components.
- Check and adjustment of the brakes.
- Check and adjustment of the entire drive train, especially the alignment of the generator.
- Documentation of the actual state of the turbine and its evaluation, as well as the performed maintenance and repair tasks.

SCADA - Supervisory Control and Data Acquisition

At present the majority of modern wind turbines are connected to SCADA systems. The SCADA system is used for remote supervision of wind turbines. All relevant turbine data can be observed and visualised. This enables the turbine operator to get data about the plan for service and maintenance from afar and information about turbine failures can be processed.

Condition Monitoring

Condition monitoring systems (CMS) can be used to continually detect any change of the condition of machinery components that may lead to a premature failure of the component. The benefit of a CMS is an early detection of damage of the monitored components, which also leads to a prevention of secondary damage. Another point is that the damages can be classified by evaluation of frequencies typical of certain components. Therefore the maintenance downtimes can be scheduled and in the optimal case also reduced. The CMS also allows a condition-oriented maintenance.

The CMS therefore results in a reduction of unplanned downtimes and in an increase in technical availability, as well as in a reduction of maintenance costs.

The use of condition monitoring systems is not profitable for all components. If a turbine is equipped with a CMS, at present mainly the following components are often monitored:

- Main bearing
- Main gearbox
- Generator
- Nacelle with tower

A 3: Failure rates of main components

In section A1 the technical availability was introduced and it was stated that this availability is limited mainly because of wind turbine failures. But it was also declared that the technical availability does not give any hints on the reliability of the wind turbine components because there is no direct relation between breakdown time and resulting costs.

A very good overview about availability of wind turbine components is given by the Royal Institute of Technology (KTH) Stockholm [49] in a survey of failures in wind turbines during 1997 - 2005. This reference presents results from an investigation of failure statistics from sources from Sweden, Finland and Germany.

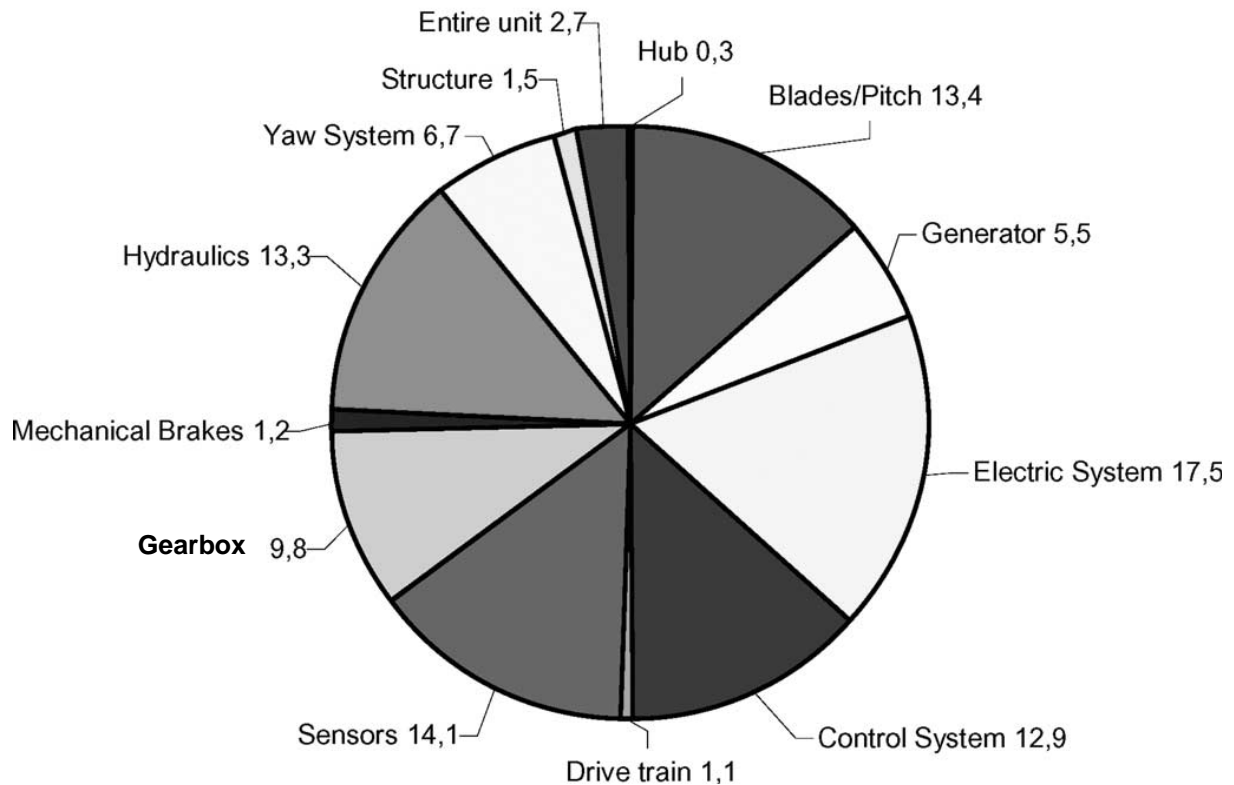

Figure A.2: Distribution of numbers of failures [49]

Figure A.2 shows the percentage distribution of failures that occurred during the years 2000 - 2004. First of all one can see that most failures are linked to the electrical system followed by sensors, and blade / pitch components. The larger main components e.g. gearbox and generator have a minor percentage on the failures.

However, Figure A.2 does not give hints about the importance of the component failures. Therefore, information about the breakdown time that is caused by each component failure is needed. This kind of information is included in Figure A.4. One can see that especially the components that have a larger failure rate, like the electric system, do cause smaller down times for each failure. In contrast, the main components that have a smaller amount of failures like the gearbox, or especially the drive train do cause a long wind turbine downtime for each failure. The different downtimes are on the one hand caused by the needed repair effort for the components but also caused by availability of replacement parts and the capacity of personnel.

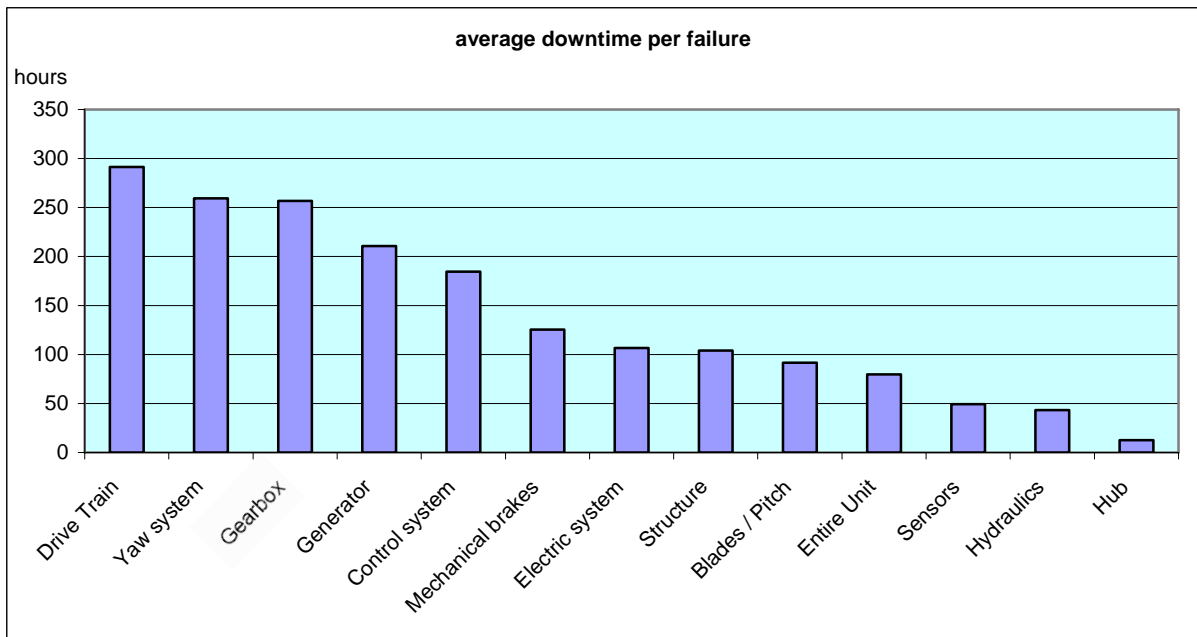

Figure A.3: Average downtime in case of component damage [49]

Comparing the failure rates of the components, see Figure A.2, with the average downtime per case of damage, see Figure A.3, the reliability of the wind turbine components can be evaluated in another way. Therefore Figure A.4 shows the distribution of downtime per component failure for the years 2000 - 2004. One can see that the gearbox that have a minor percentage of failures, do cause the longest wind turbine downtime, closely followed by the control system and the electric system. Furthermore it becomes obvious that also failures of components that are focused by the PROTEST project, e.g. the gearbox and also the yaw system cause large downtime, although it was mentioned earlier that they have a minor percentage of failures.

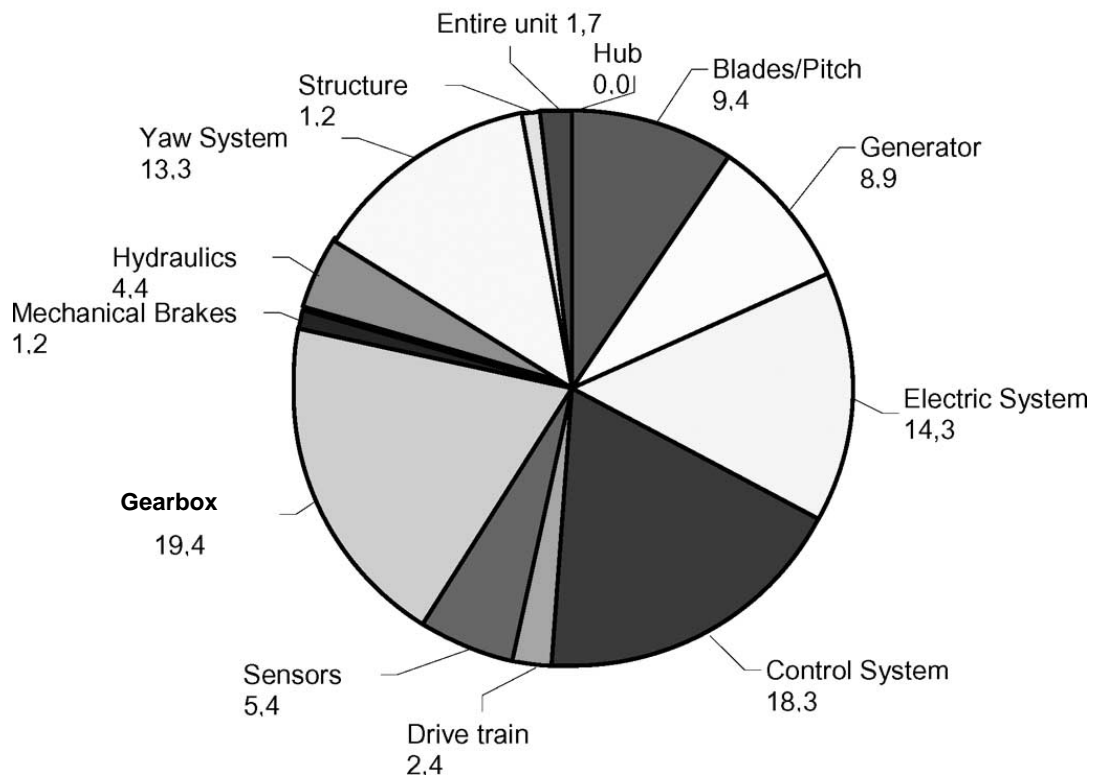

Figure A.4: Percentage of downtime per component in Sweden (2000-2004) [49]

However, a final rating about the most severe component failures can be concluded not until the costs that are caused by the different component failures are evaluated. (see section A4) Nevertheless, for a typical wind turbine 20% of the downtime is due to gearbox failures and an average gearbox failure takes about 256h to repair. Since the gearbox causes the largest downtime of wind turbines in Europe, a closer look at this component is meaningful.

Year	1997	1998	1999	2000	2001	2002	2003	2004	1997-2004
Number of failures	21	41	52	26	30	42	13	7	232
Total downtime (hours)	4031	2518	5061	6172	5228	12589	3987	2309	41895
Average downtime per failure (hours)	192	61	97	237	174	300	307	330	181
Percentage of total downtime (%)	9,4	5,3	7,3	15,5	13,6	33,5	14,8	17,4	14,6

Table A-4: Overview of data for gearbox failures in Sweden from 1997 to 2004 [49]

Table A-4 gives an overview about the gearbox failures in Sweden between 1997 and 2004. As well the total number of failures and the total downtime of the turbine caused by these failures are given. This data is used to present the average downtime per gearbox failure. The most interesting data is shown giving the turbine downtime caused by gearbox failures as a percentage of total turbine downtime.

One can see that during the years the total number of gearbox failures is decreasing, while the average downtime per failure is clearly increasing. Combining these statements, it is shown that the percentage of turbine downtime that is caused by gearboxes is increasing in the referenced period of time. This trend shows that the gearbox will remain the most critical component for the next time and that it should be focussed when talking about increasing the wind turbine technical availability.

Type of reported failure code	Component	Number of failures	Average downtime (hours)	Number of failures, Cause: B1	Average downtime, Cause: B1 (hours)
I-1	Bearings	41	562	36	601
I-2	Gearwheels	3	272	2	379
I-3	Shaft	0	0	0	0
I-4	Sealing	8	52	4	30
I-5	Oil system	13	26	5	36
I-other	Not specified	44	230	19	299

Table A-5: Type of gearbox failure [49]

Table A-5 shows the gearbox subcomponents that cause the majority of the gearbox failures. Each type of failure has a specific code assigned to it on the report form that is used to collect the data. The letter "I" identifies the gearbox and the subsequent number is the code for the gearbox substructure that caused the failure. The last two columns show category "B1-failures" which means failures caused by wear.

Table A-5 clearly shows that most of the gearbox failures are caused by gearbox bearings and that the damage of the bearings is mostly caused by wear. Also the highest downtime is caused by failures of the gearbox bearings. As another fact one can see that the downtimes due to failures caused by wear are higher than downtimes caused by other failures.

A 4: O&M costs and loss of production associated with failure of main components

In the last sections the relevance for component failures was evaluated by means of its influence on the technical availability of the entire wind turbine. The technical availability has a major influence on the costs that are caused by component failures, but there is no direct relation between technical availability and overall costs that are caused by component failures. Therefore different kinds of costs have to be considered.

The averaged costs that are caused by the loss of production are directly linked to the technical availability. If a wind turbine has a technical availability of 98%, this means the turbine can only earn 98% of the optimum energy yield. A technical availability that differs for 1% affects the energy yield and the related revenues for more than 1%, since downtime is over proportionally correlated with high wind speed conditions. This means, a reduced technical availability often leads to inferior economics.

The technical availability is on the one hand related to the reliability of the wind turbine components but also on the availability of the component replacements and service teams. A large number of service teams and component replacements, kept available for unforeseen repairs, lead to a higher availability of the turbines, but this also leads to additional costs.

Another type of costs is based on the costs for component replacements. Depending on the failing component and the kind of fault, this kind of cost can be only a small part of the overall costs, but it can also be a major cost factor.

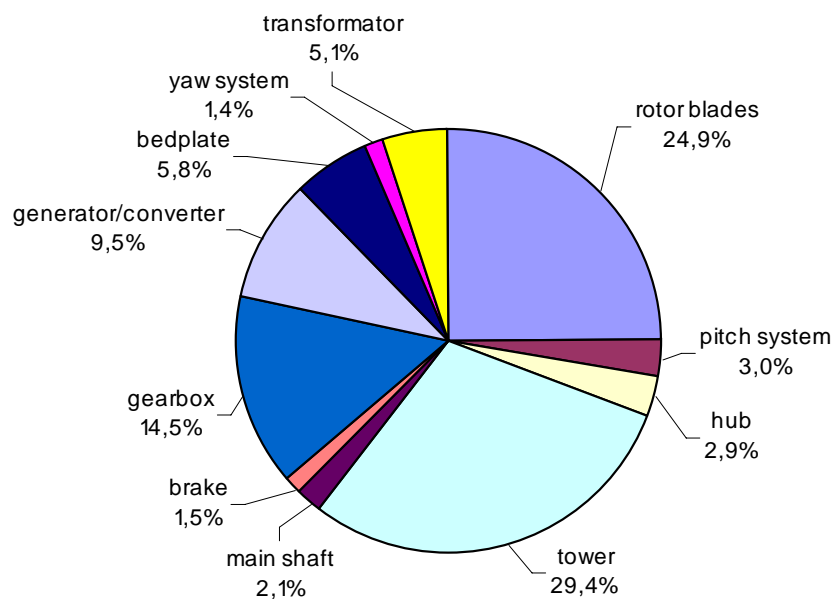

Figure A.5: Relative component costs for a state-of-the-art wind turbine with rated power of about 2MW

Figure A.5 gives an overview about the relative distribution of component cost of a typical wind turbine with a rated power of about 2MW. The figure gives an idea about the replacement costs for different components. A major failure of the gearbox that causes a need for a replacement of the entire gearbox leads to replacement costs of about 14,5% of the entire wind turbine. The other costs caused by loss of production or personnel for the replacement, as well as needed craned are not even included.

A 5: Prospects for improvement of profitability for manufacturers and operators

It can be concluded that the most important factor for the economics of wind turbines is the technical availability. On the one hand the technical availability can be kept high using an effective maintenance and inspection approach. Therefore it should be thought about the application of modern strategies, such as condition-based also reliability centred maintenance. Therefore the use of condition monitoring systems can also be very effective.

But on the other hand the technical availability is dependent on the wind turbine components. Since the durability of the components also affect the maintenance and repair costs, it is even more important to optimise the components in relation of their durability. The component that causes the largest reduction of operating efficiency has been identified as the gearbox, followed by the electrical and the control systems. The focus of further developments should be on these components.

Since the trend to the implementation of individual pitch control systems can be seen for future wind turbines, an increase in the loading of pitch systems can be expected. Therefore the consideration of the pitch actuator system in the future development becomes even more relevant.